

# Spin and nuclear spin dependent transport in quantum dots

K. Ono<sup>1</sup> and S. Tarucha<sup>1,2,3</sup>



<sup>1</sup>Department of Physics, Univ. of Tokyo



<sup>2</sup>NTT Basic Research Laboratories



<sup>3</sup>ERATO, JST

## Outline

- ◆ Double quantum dot
- ◆ Spin blockade in two-electron double quantum dot
- ◆ Electron spin-nuclear spin interaction in spin-blocked double dot
- ◆ NMR response of leakage current in spin blockade regime
- ◆ Summary

# Transport measurements

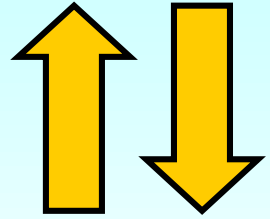

Coulomb blockade,  
Single electron tunneling

Electron Charge in QD

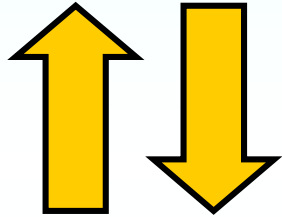

+ Pauli exclusion,  
Zeeman effect

Electron Spin in QD

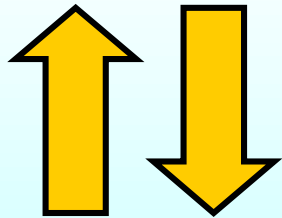

+ Hyperfine interaction,  
Overhauser effect

Nuclear Spin in QD

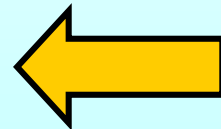

NMR rf radiation

# Quantum Dots

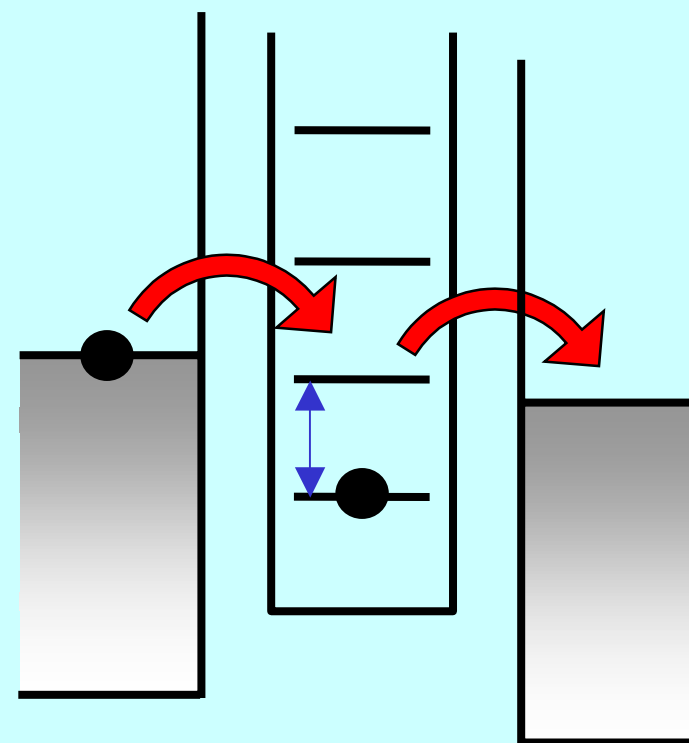
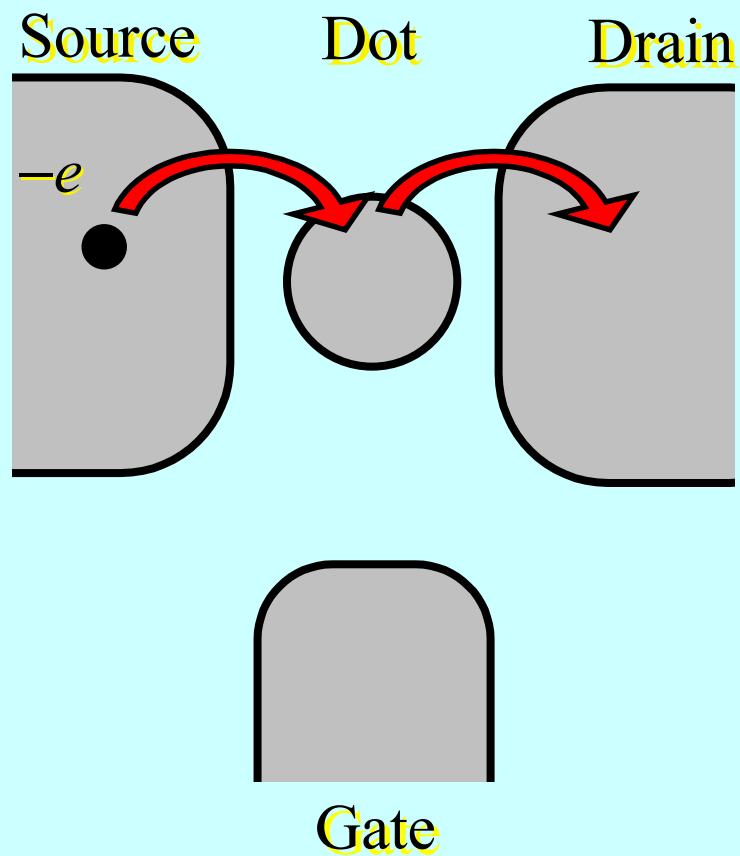

Addition energy

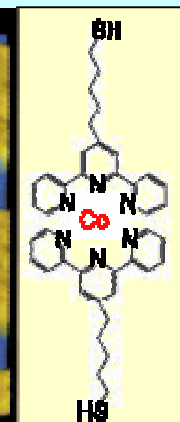
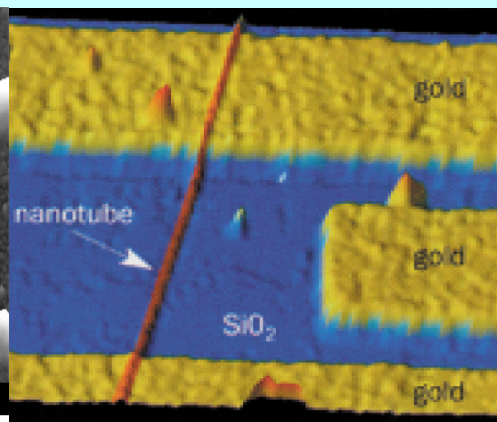
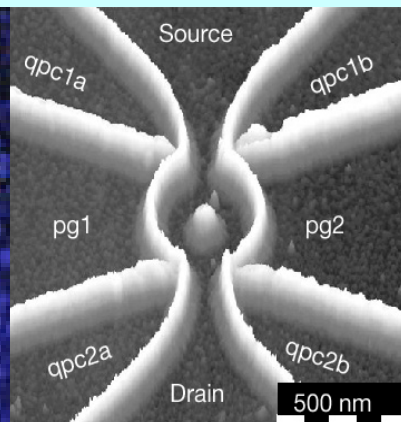
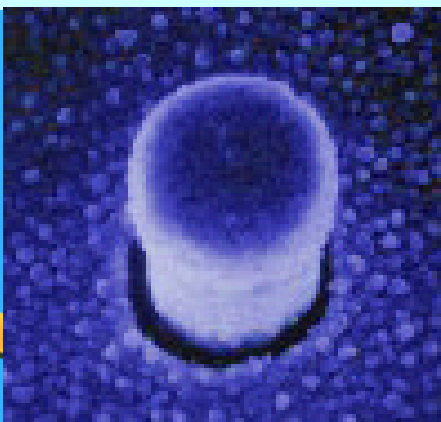
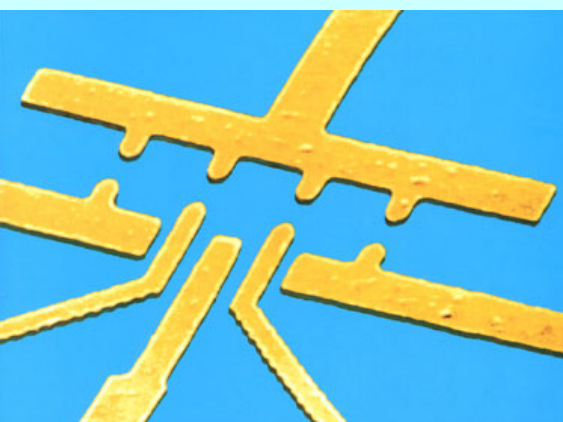

# Vertical Quantum Dot

Mesa diameter 0.5-0.6 $\mu\text{m}$

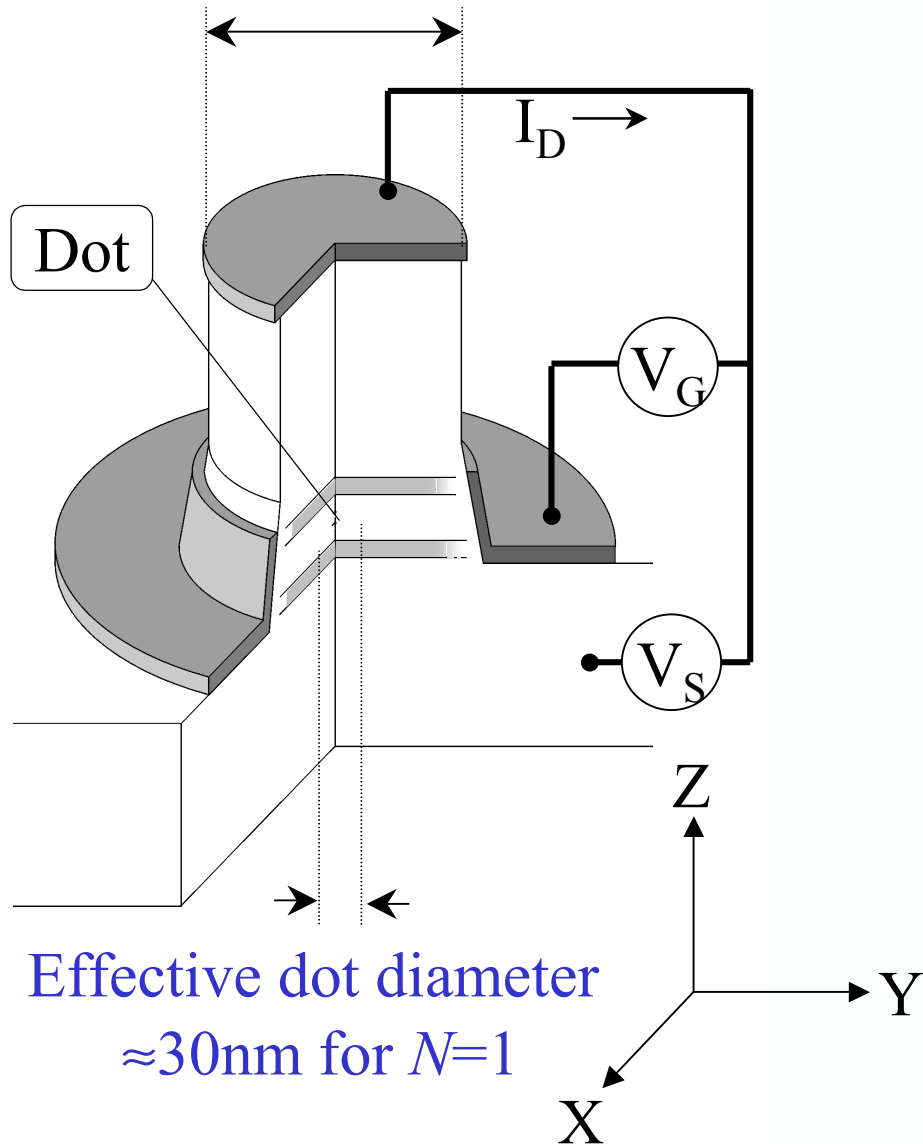

*Reservoirs* gradient doped n-GaAs

*Barriers*  $\text{Al}_{0.22}\text{Ga}_{0.78}\text{As}$  6-12nm

*Well*  $\text{In}_{0.05}\text{Ga}_{0.95}\text{As}$  12nm

*Ohmic/Schottky contacts* TiAu

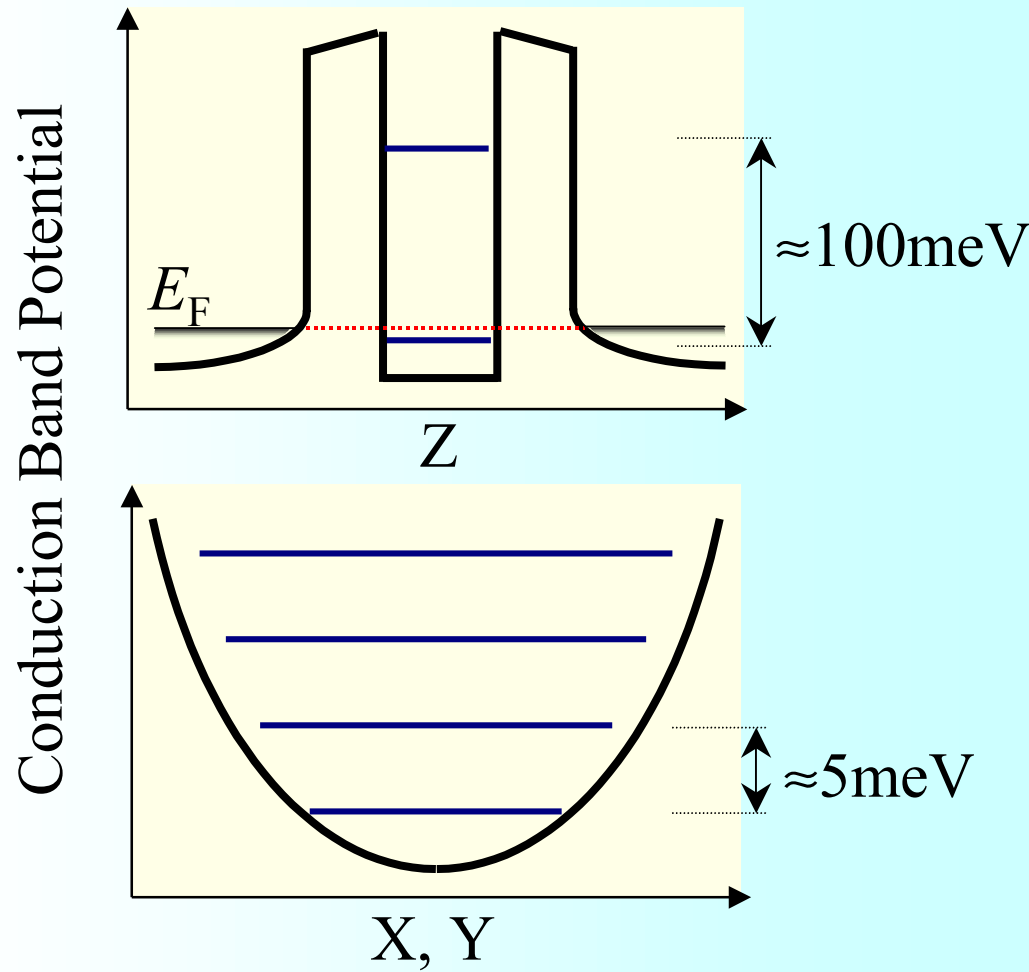

# Fock-Darwin States:

A two-dimensional harmonic oscillator in magnetic field

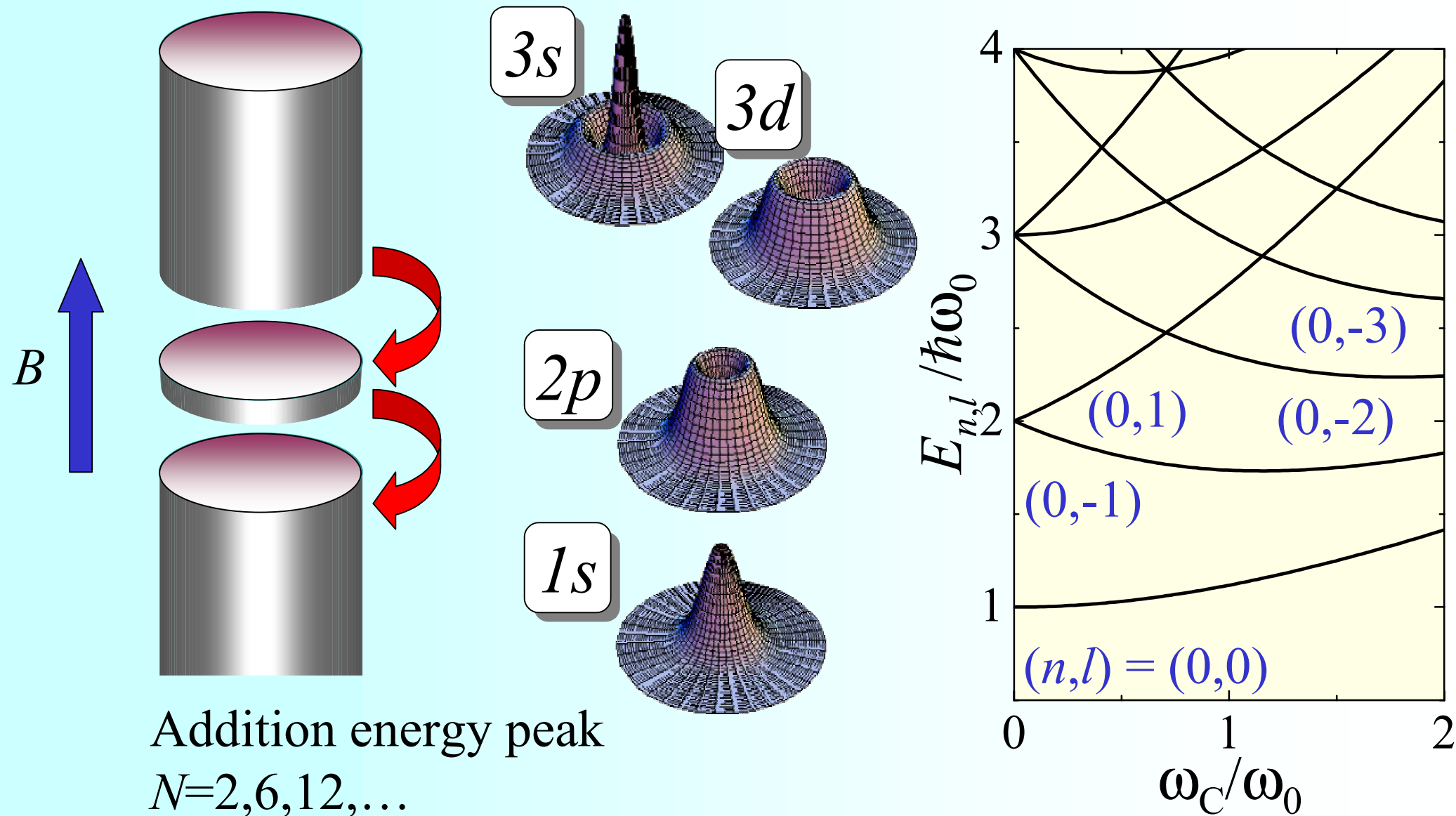

# Vertical double quantum dot

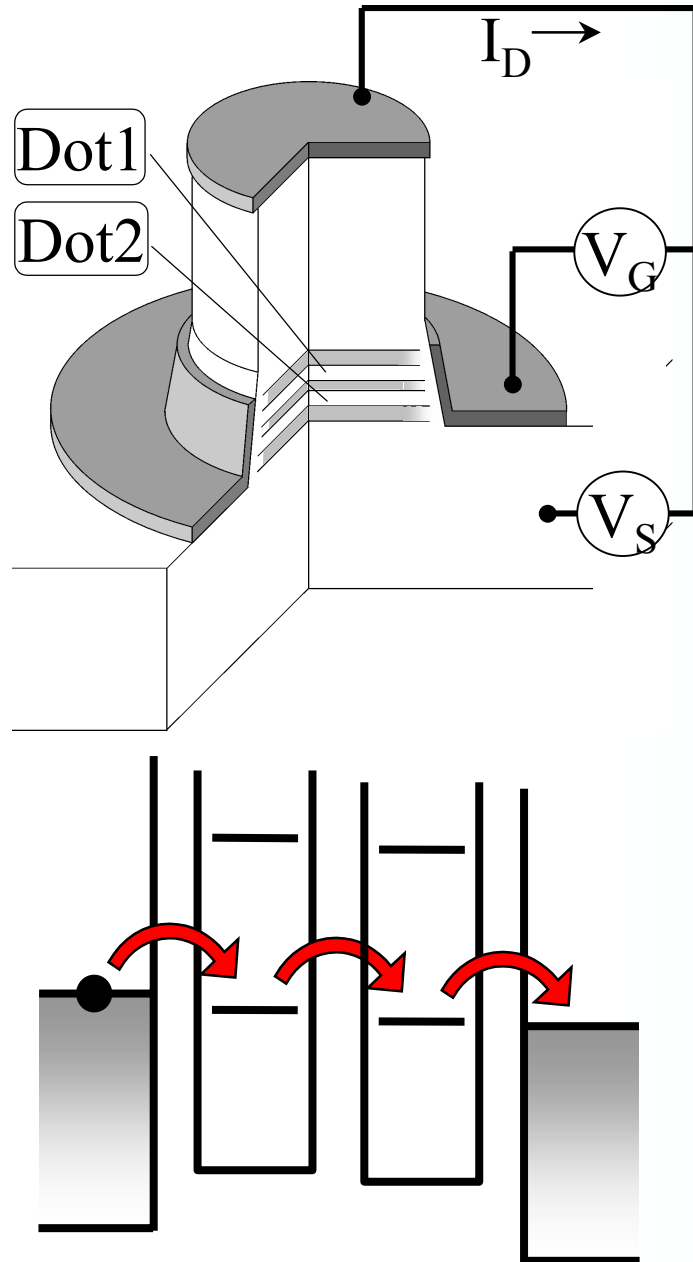

3-step sequential tunneling  
via two circular disk  
shaped quantum dot

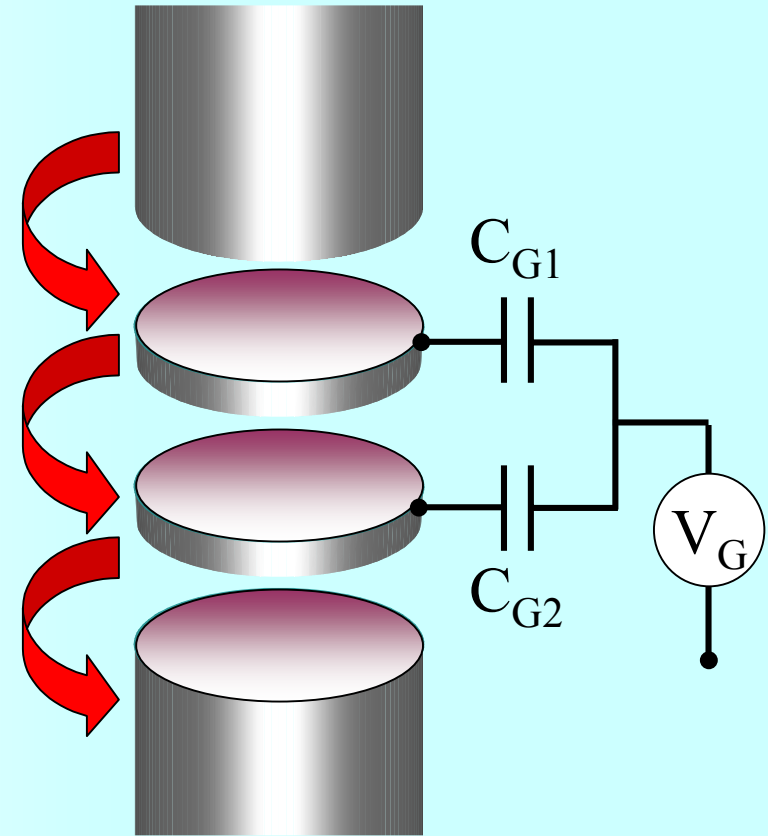

One gate electrode couples  
to two dots

# Inter-dot energy offset

Small mesa diameter leads to reduced electron density in one reservoir, which cause energy offset between dots even for  $V_S=0$

Decrease Mesa diameter

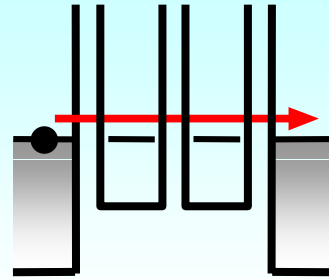
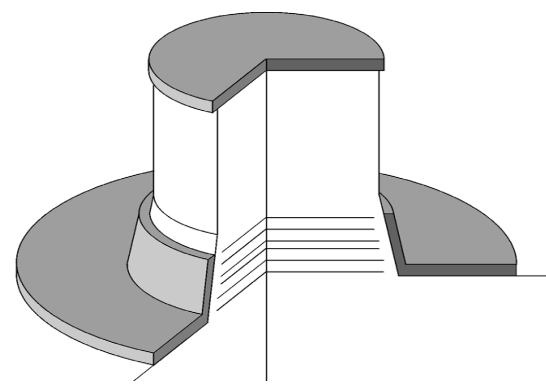

$V_G$  More positive

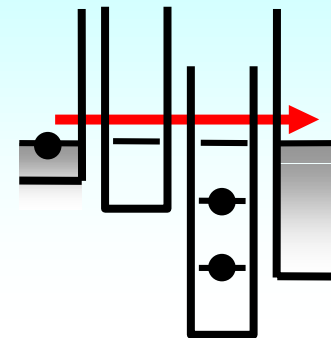
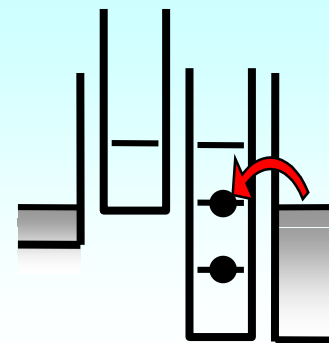
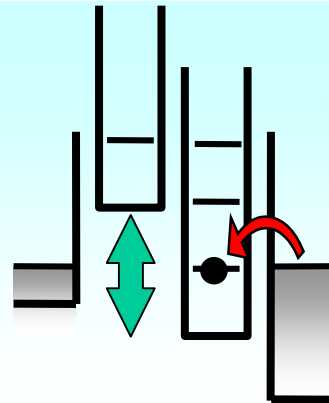
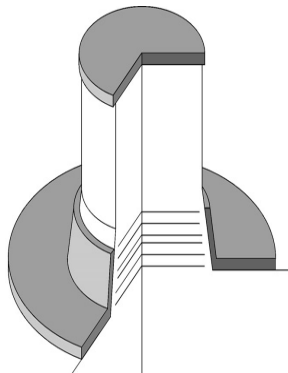
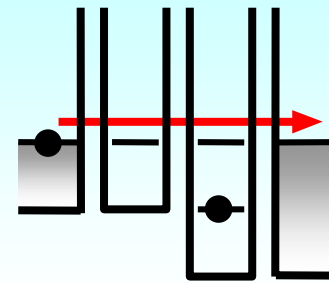
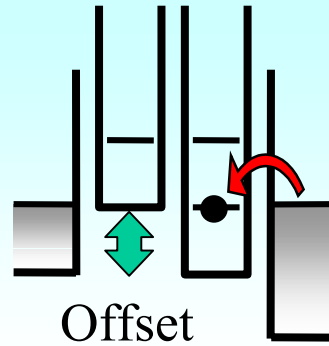
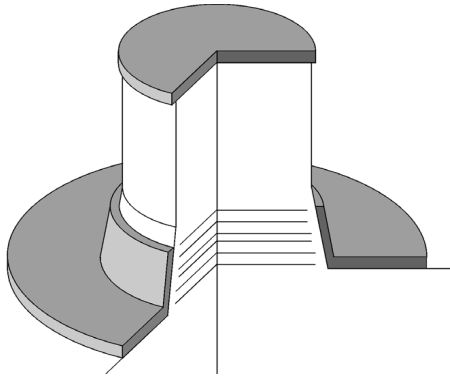

# Asymmetric double quantum dot

One electron is trapped in Dot2

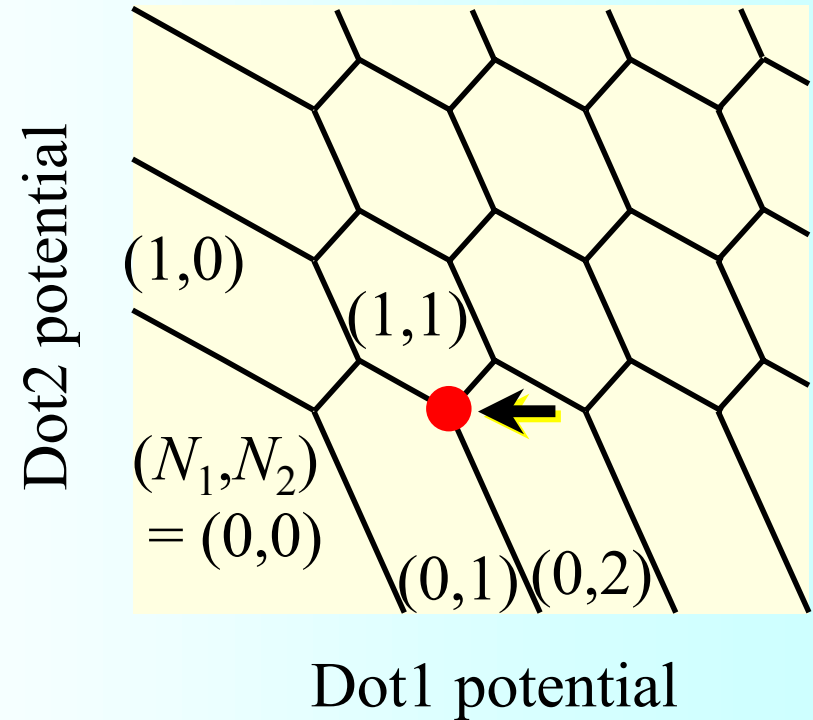
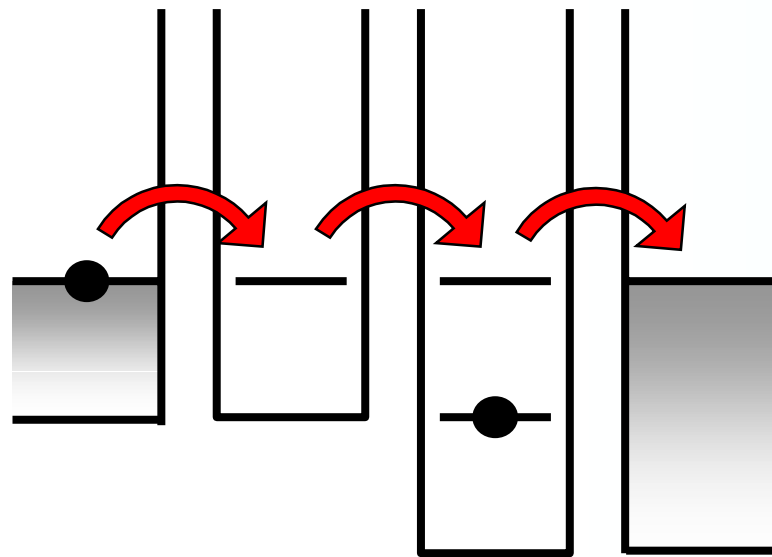
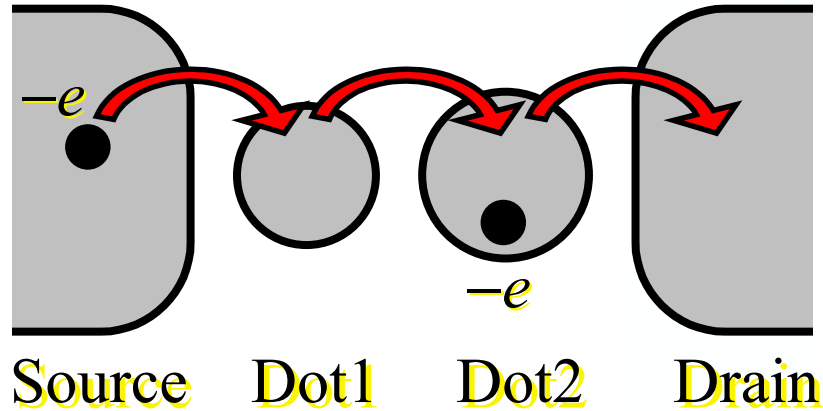

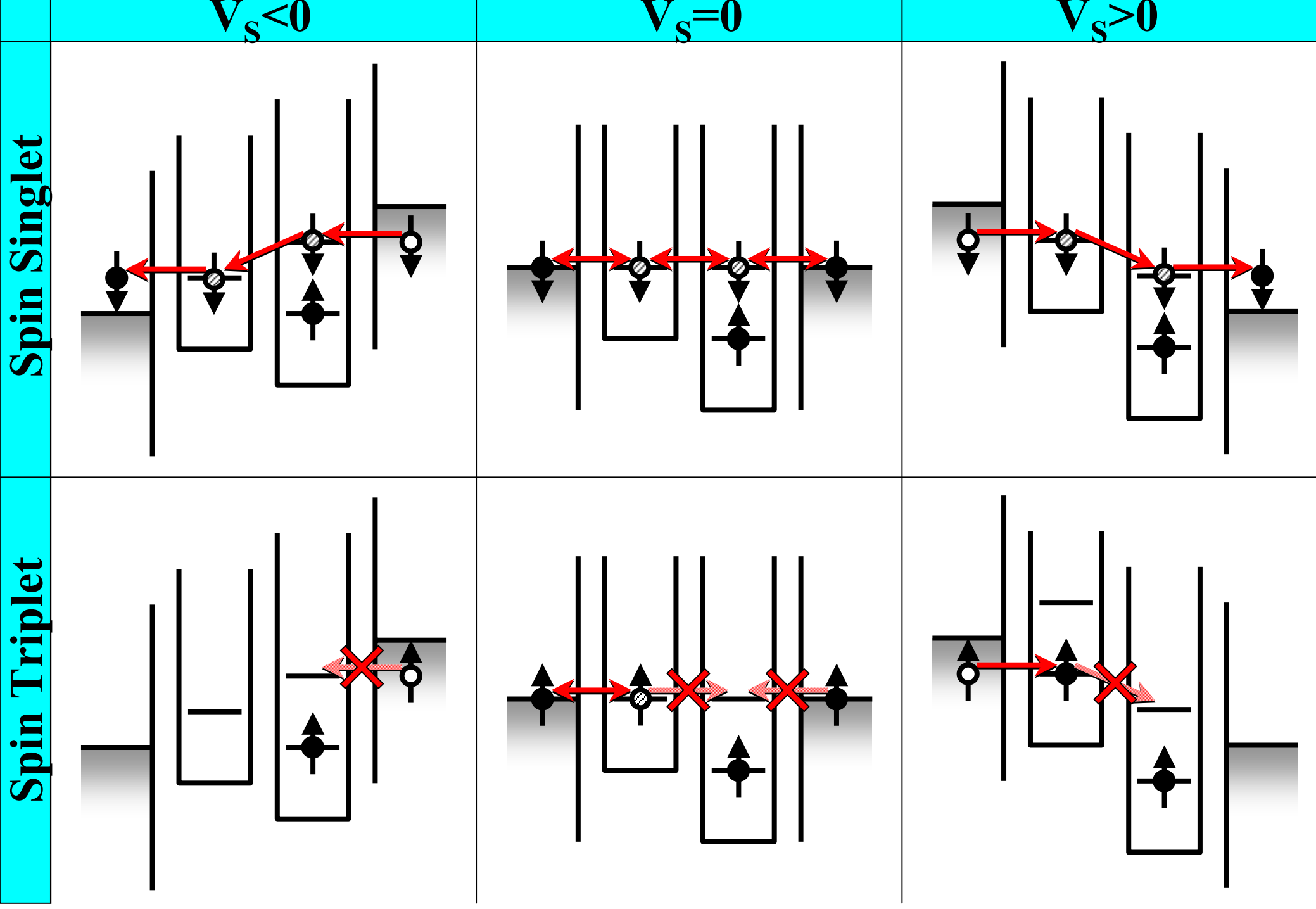

# Spin blockade ( $V_s > 0$ )

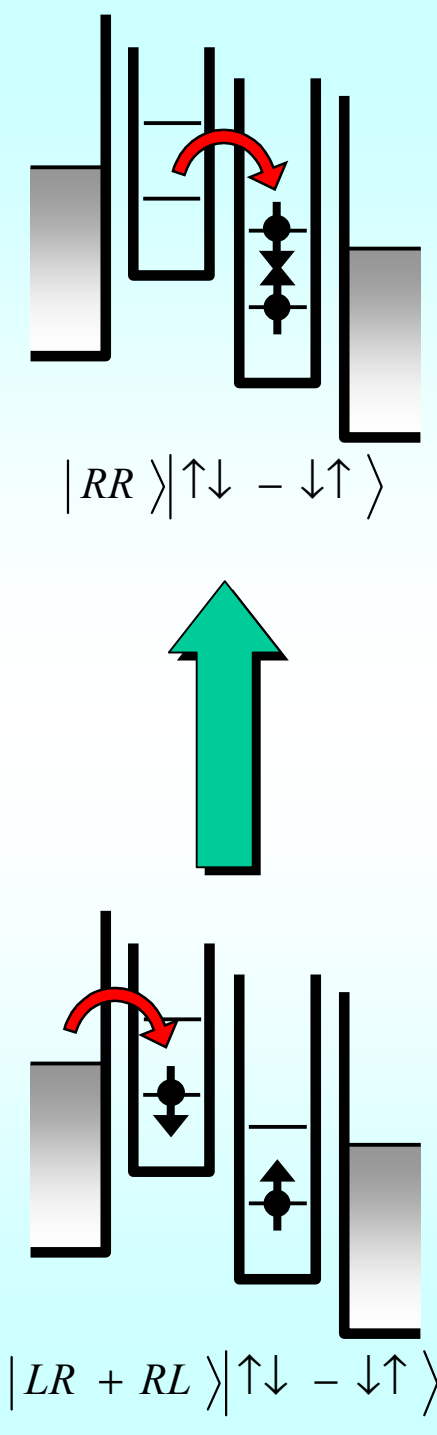
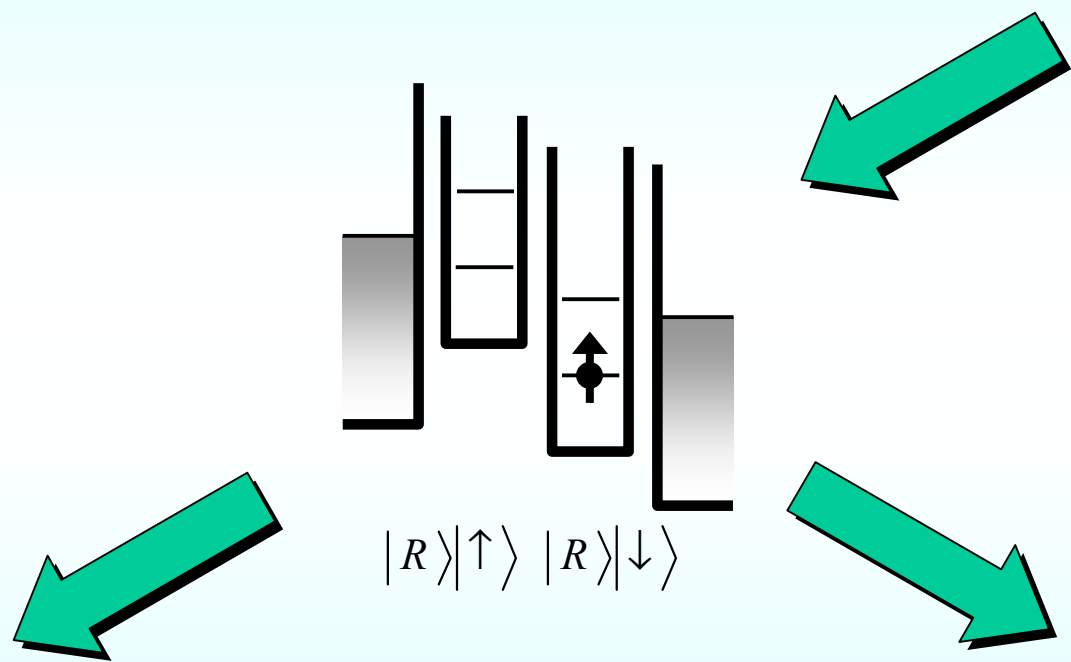
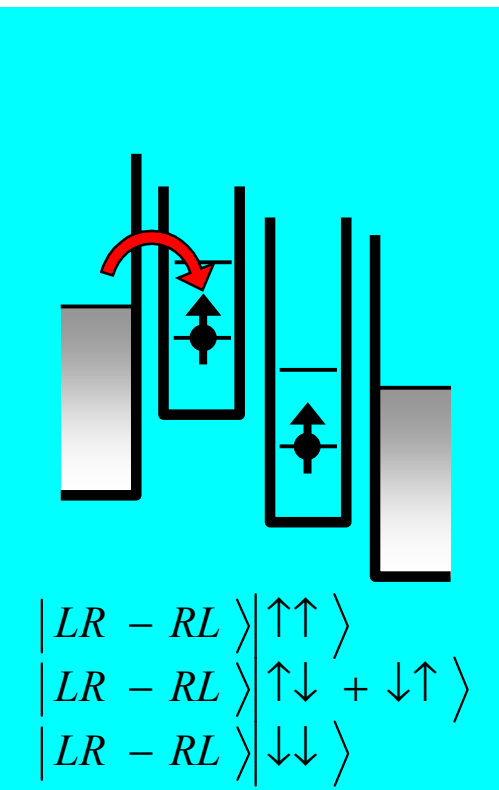

# Current rectification in double dot

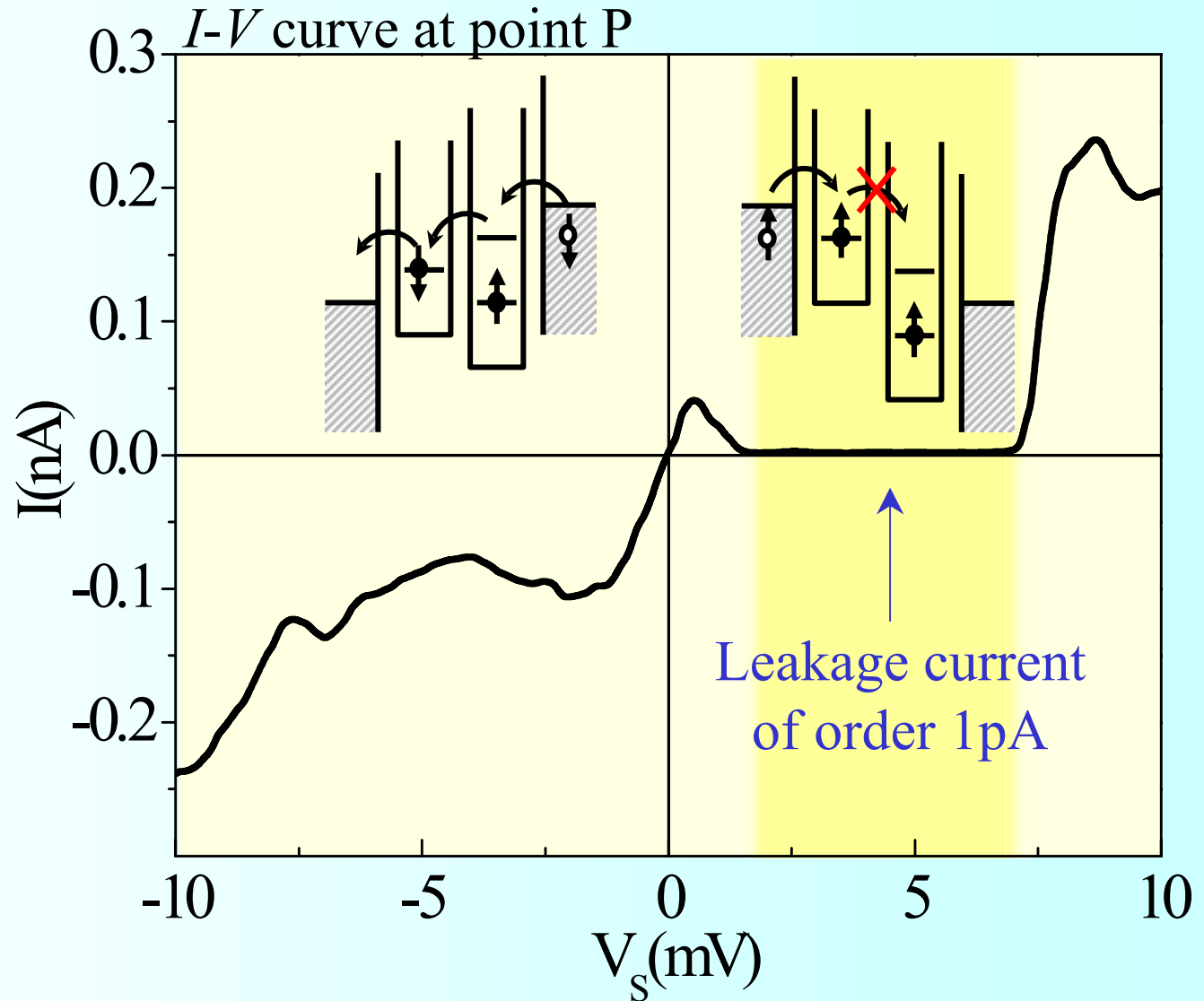
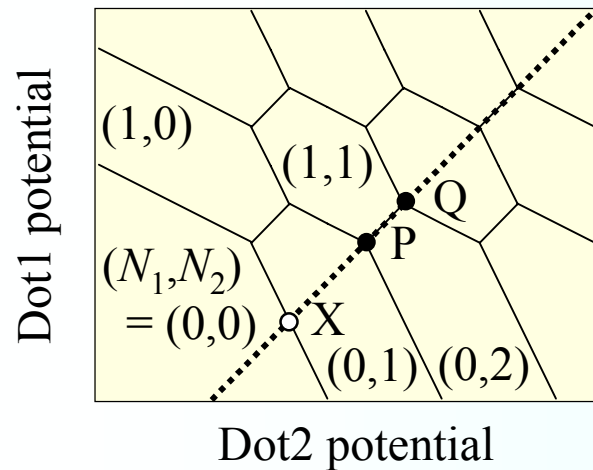
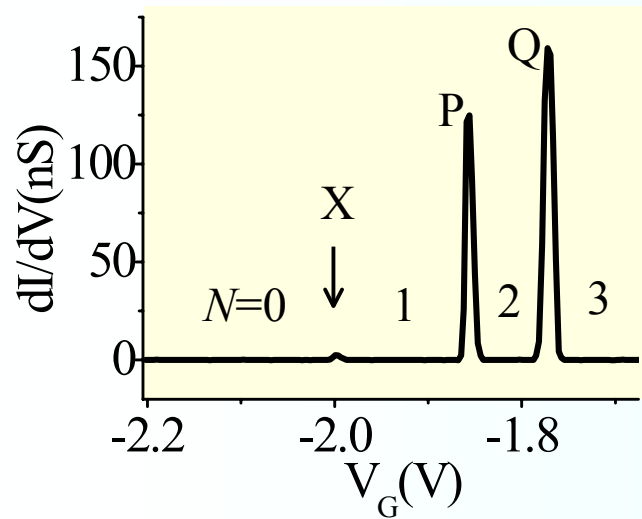

# Coulomb diamonds and spin blockade

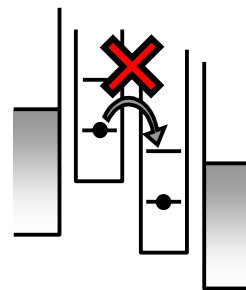
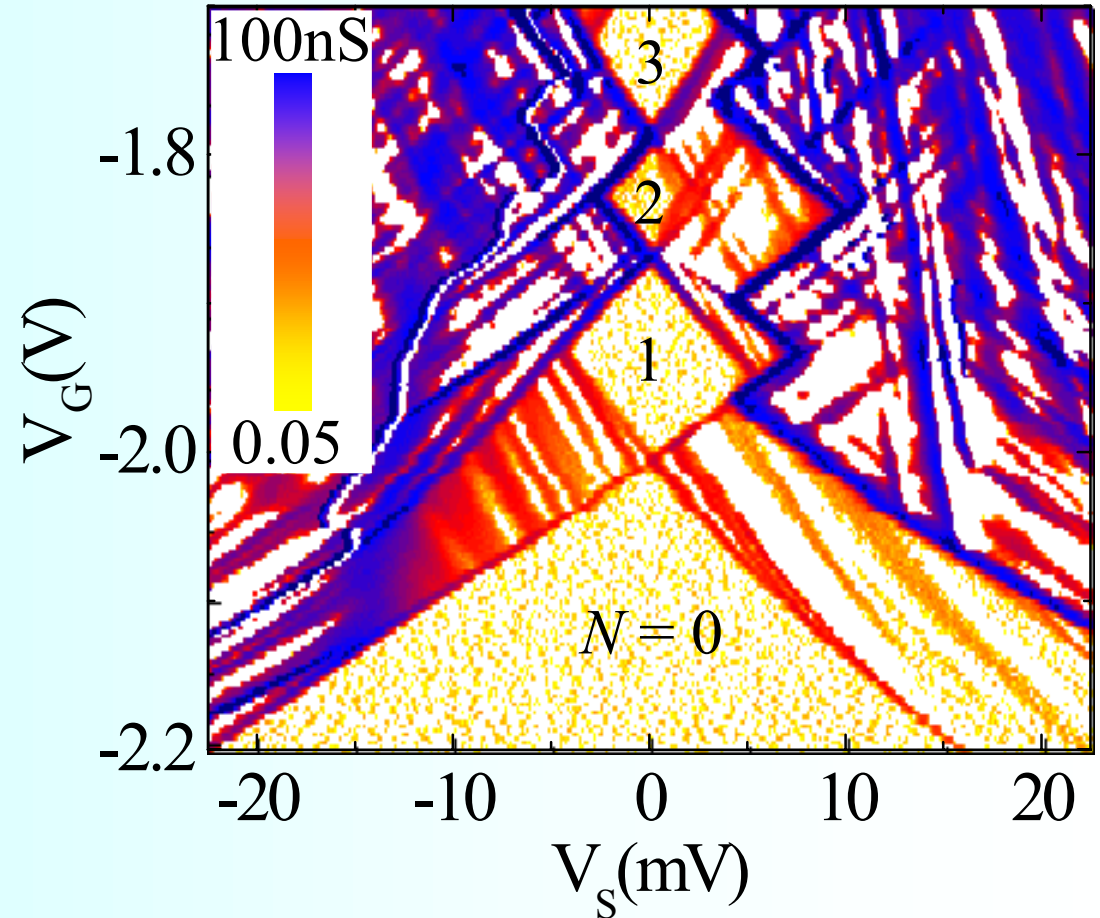
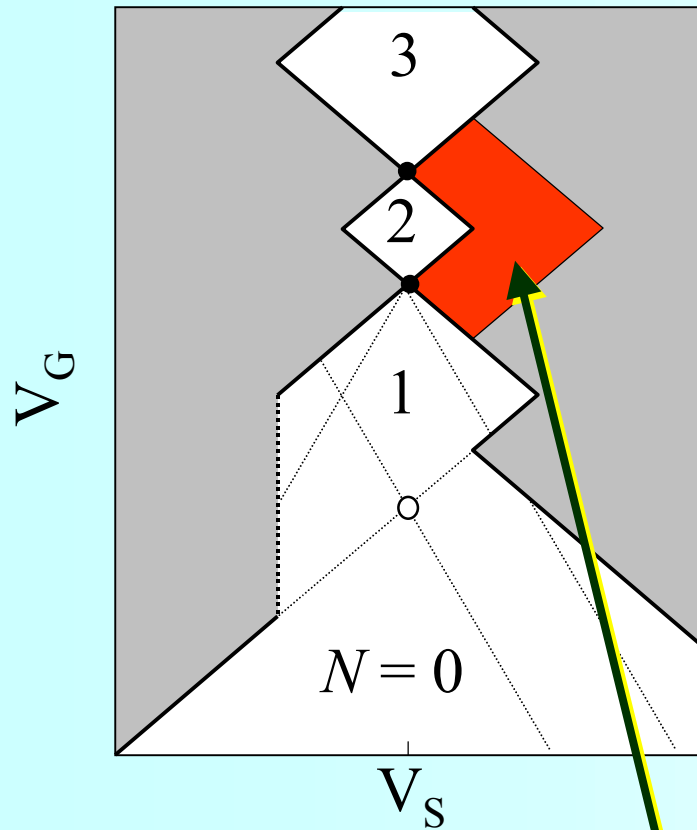

Current is suppressed if  $(N_1, N_2) = (1, 1) \rightarrow (0, 2)$  is not allowed.

# Effect of higher orbital state in magnetic field

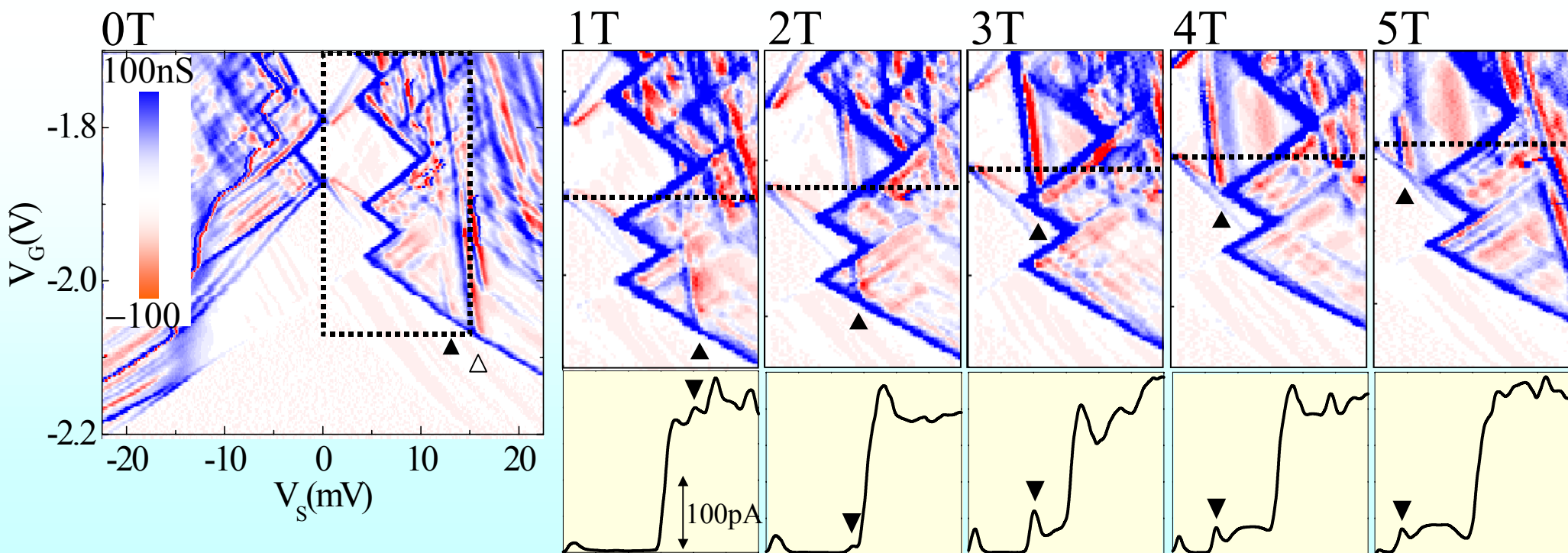
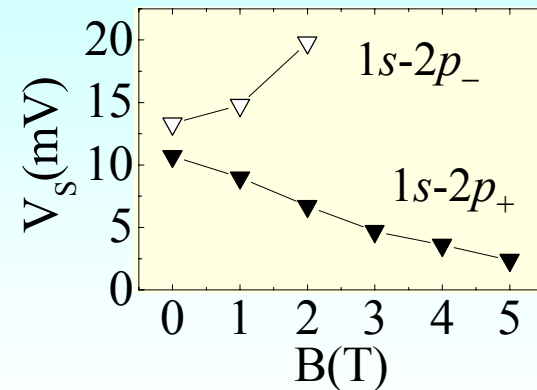
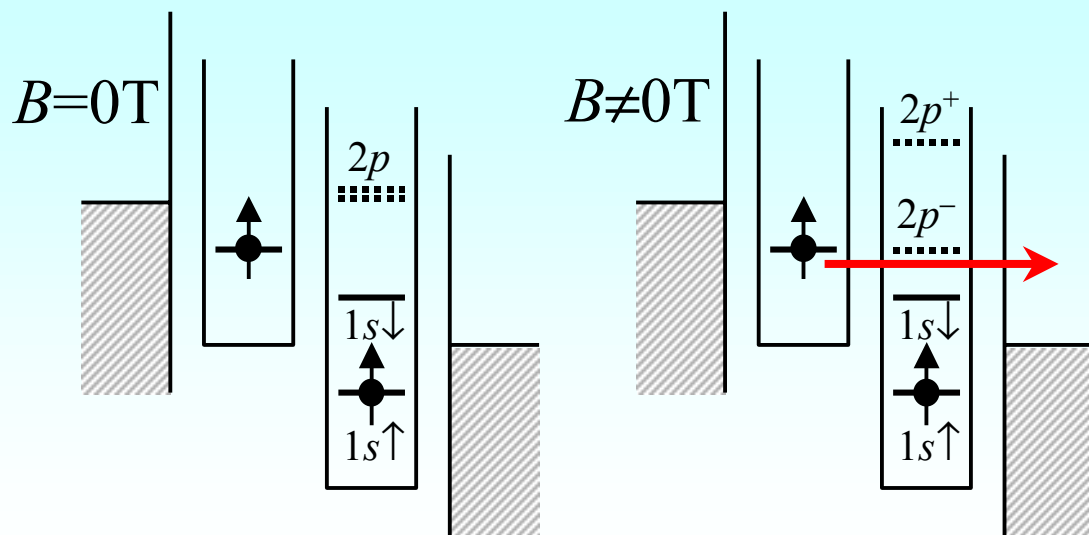

# Magnetic field dependence leakage current

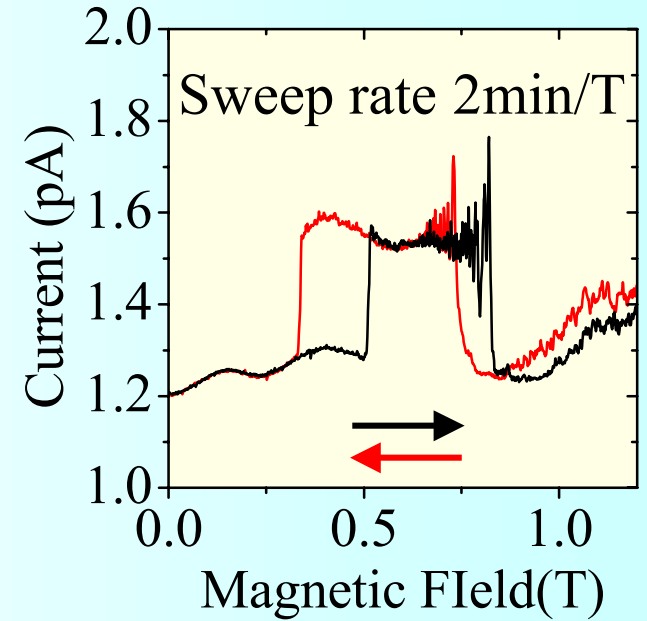
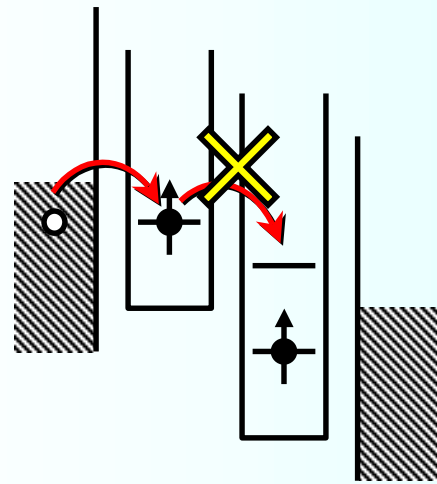
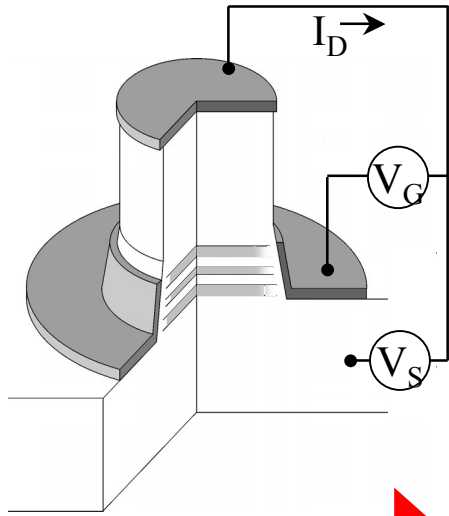

$B$  Applied parallel to the barrier to suppress orbital response

⊗ Observed only within the spin blockade region

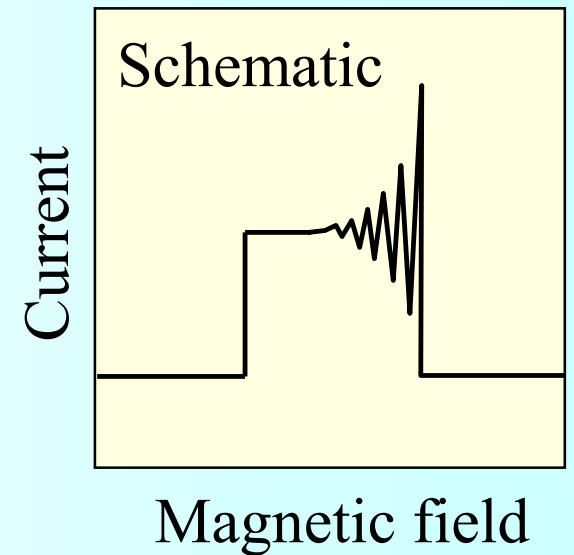
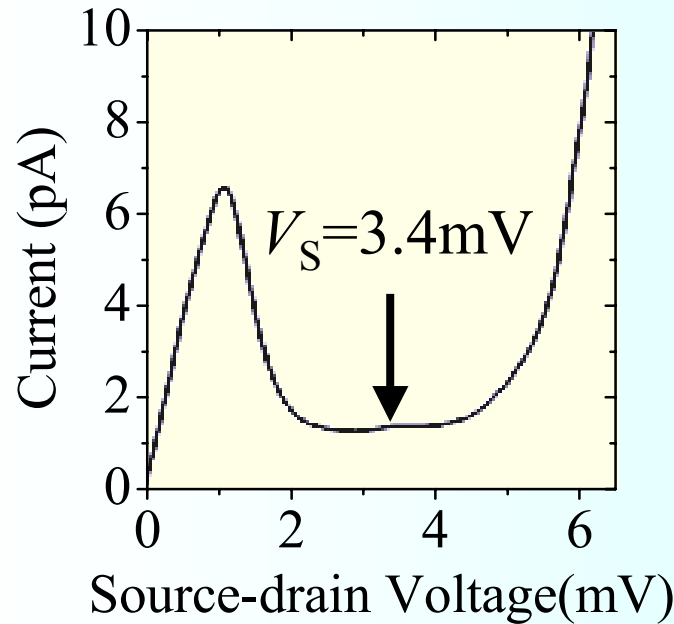

# Time-dependent oscillation of leakage current

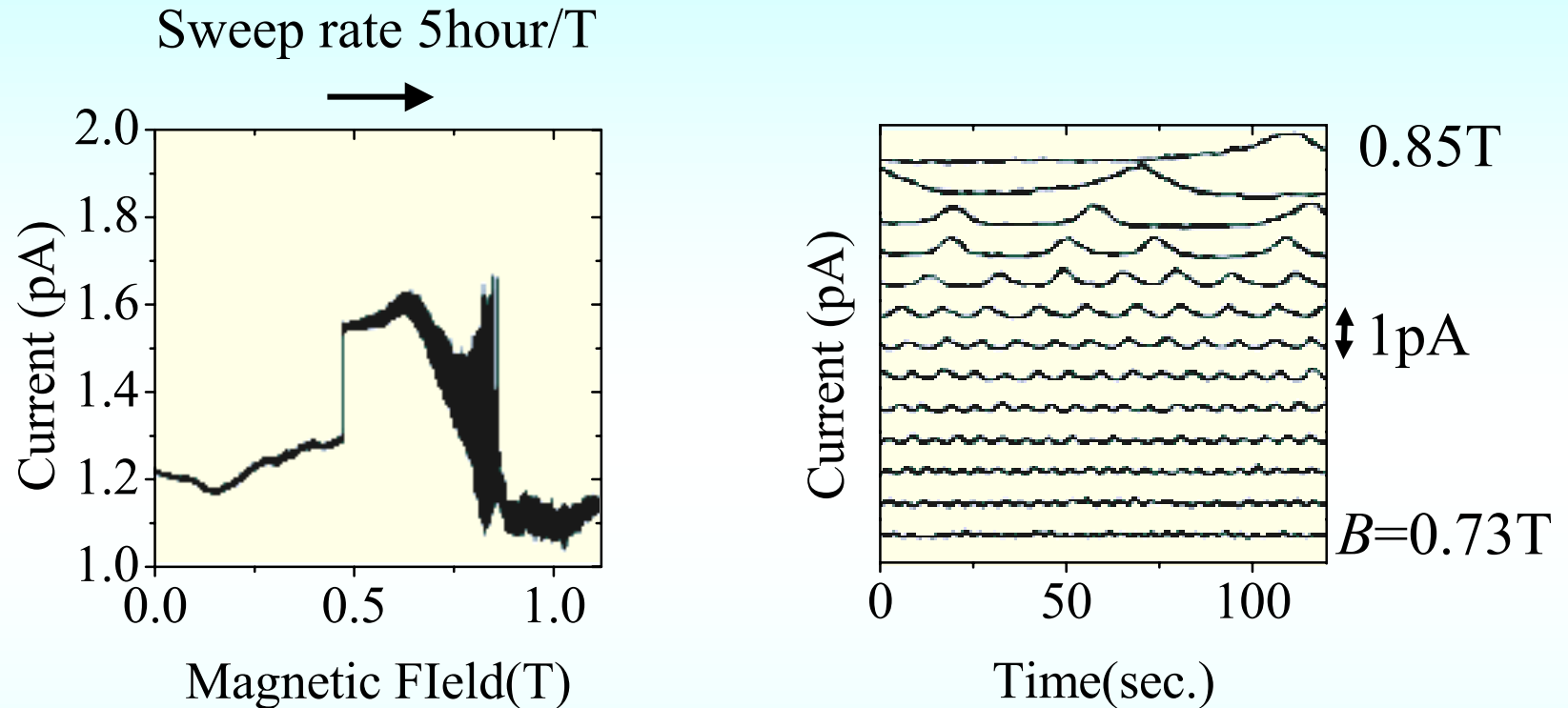

Periodic current oscillation are observed at  $B \approx 0.7-0.85\text{T}$ .  
Both of the oscillation period & amplitude increase with  $B$ .  
Maximum period  $\approx 0.85\text{T}$ , holds  $\geq 15\text{hr}$ .

# Transient behavior of current oscillation

Spin blockade region  
with oscillating leakage current

Threshold of  
 $N=2$  Coulomb Blockade

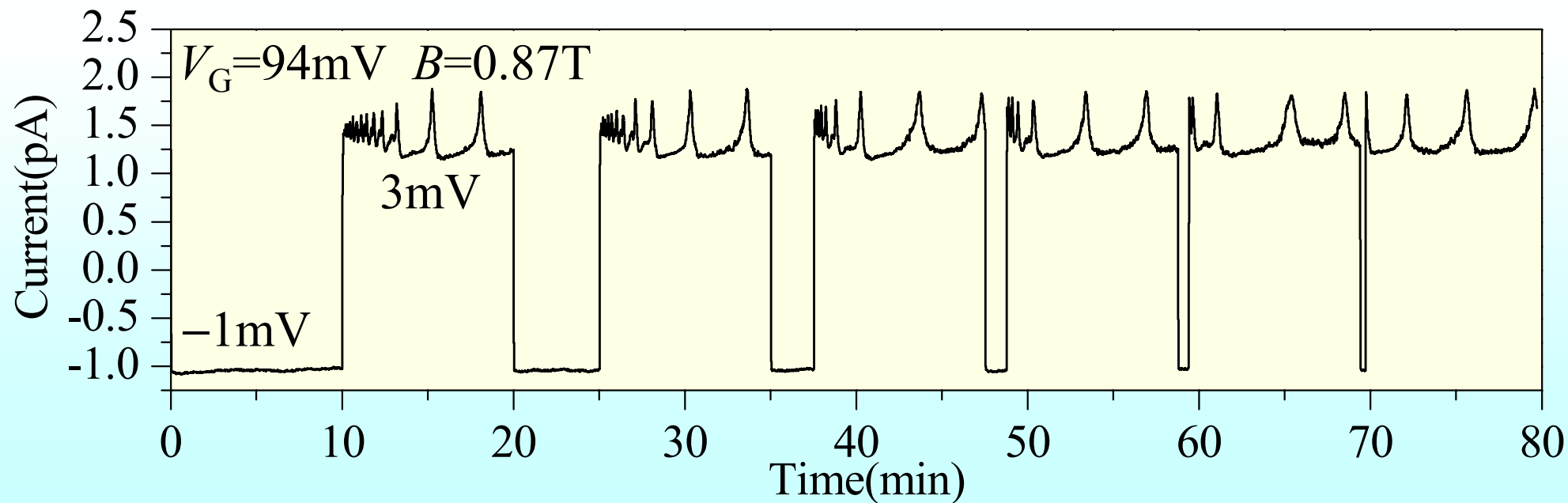
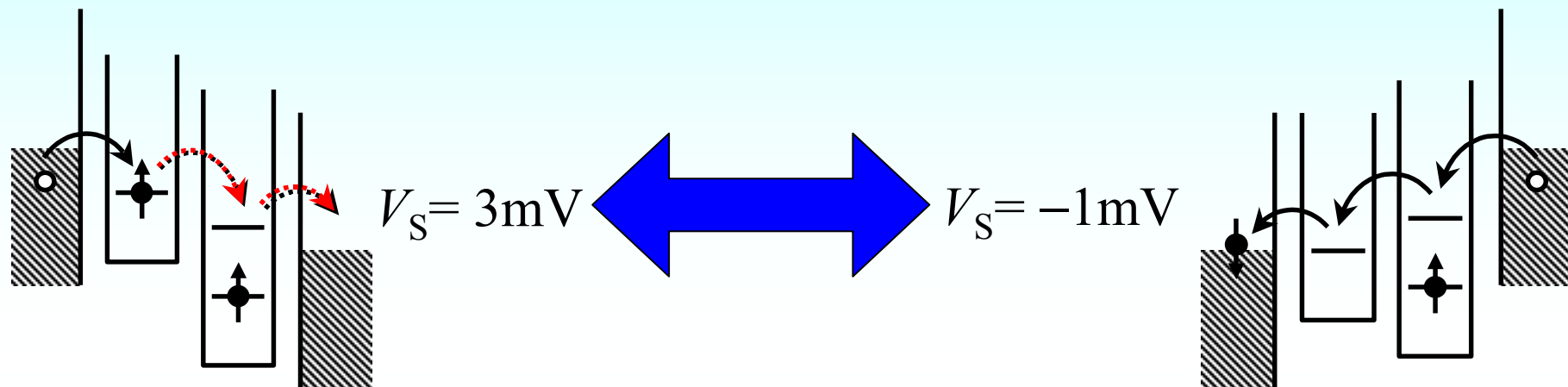

# Current oscillation in NMR rf field

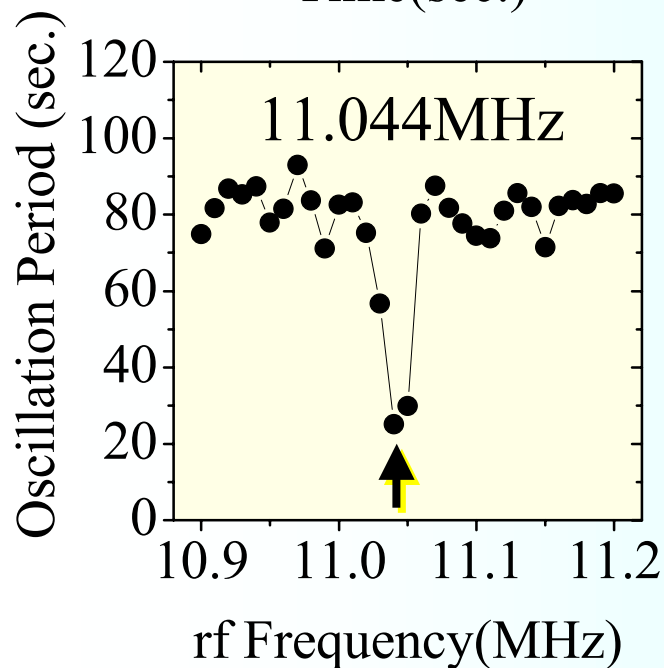
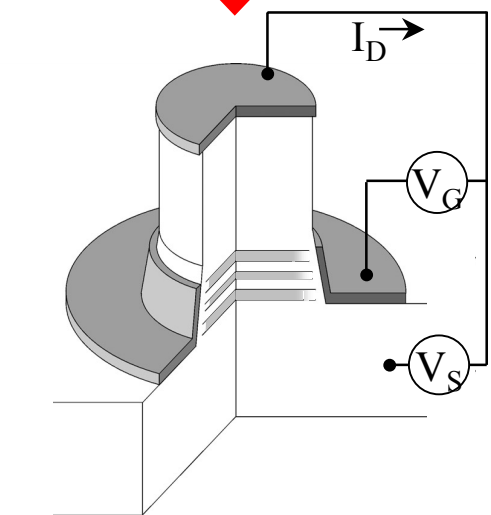
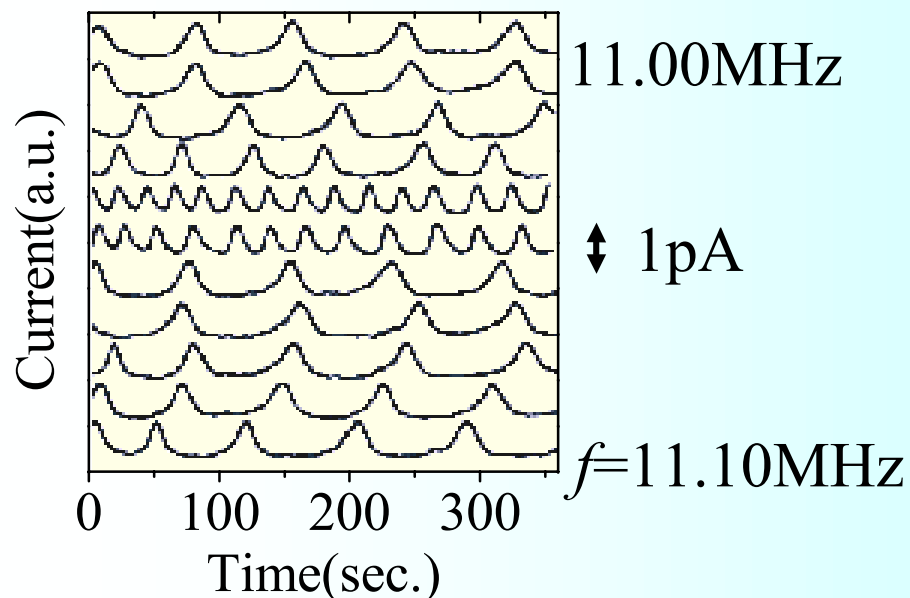
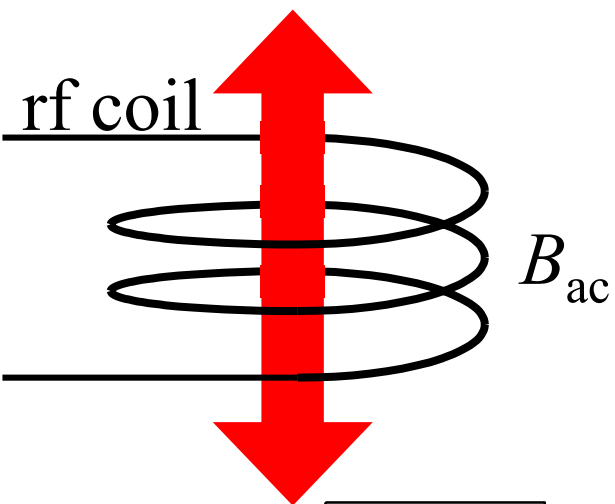

Normalized Resonant Freq.

Experiment

12.992MHz/T

$^{71}\text{Ga}$  resonance from Databook

12.984MHz/T

Line width  $\approx 0.02\text{MHz}=1.8\text{mT}$

# ◆ NMR vs. Magnetic field for $^{71}\text{Ga}$

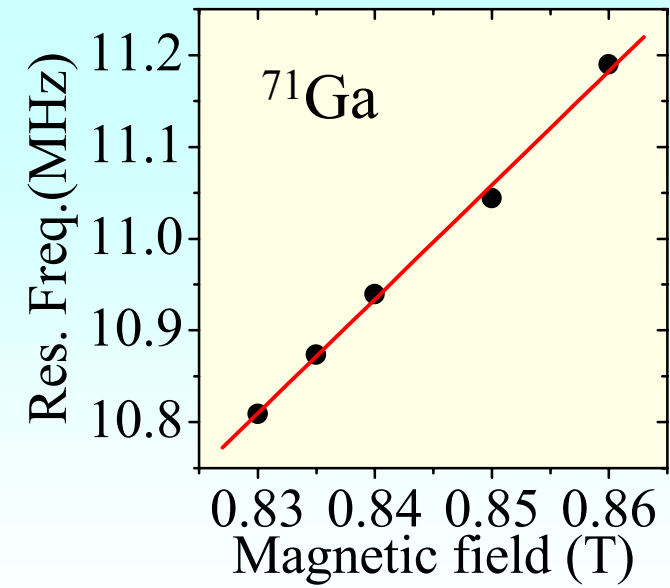

# ◆ NMR for $^{69}\text{Ga}$

Experiment  
10.205 MHz/T  
Databook  
10.219 MHz/T

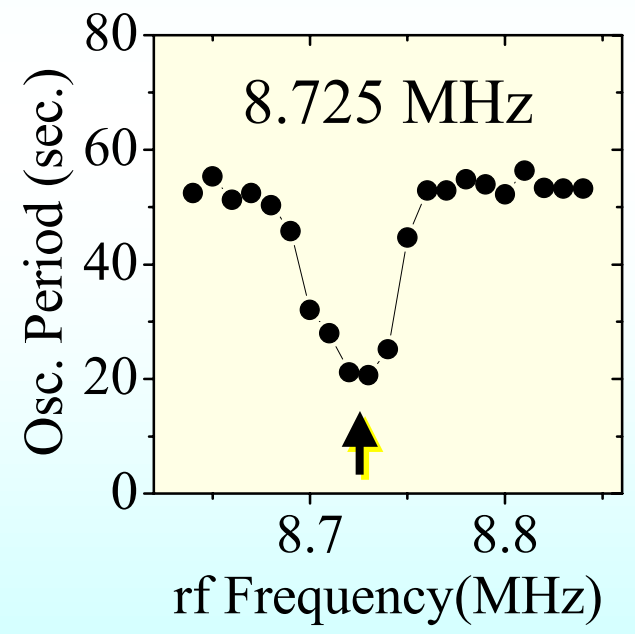
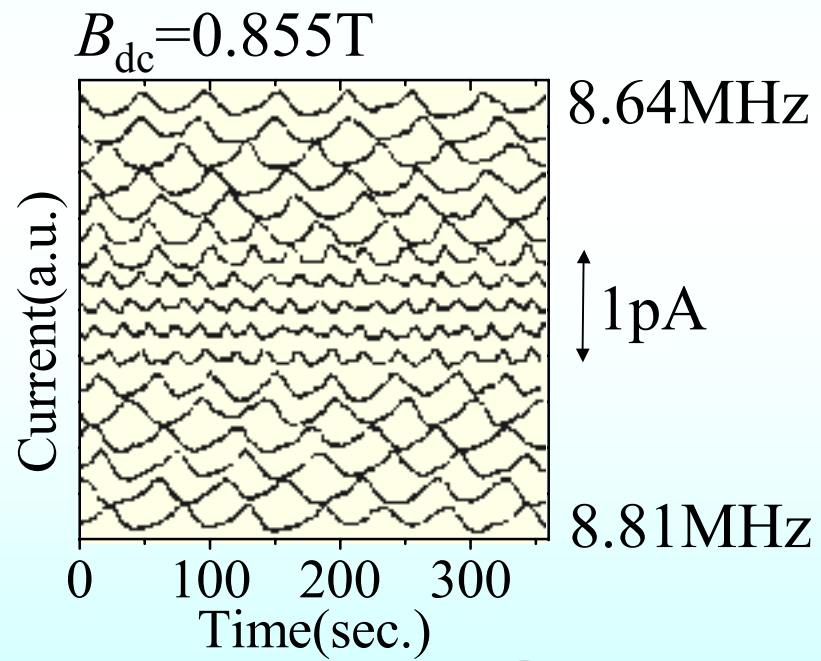

# ◆ NMR for $^{75}\text{As}$ not observed



# Nuclear spin field $B_N$ and current oscillation

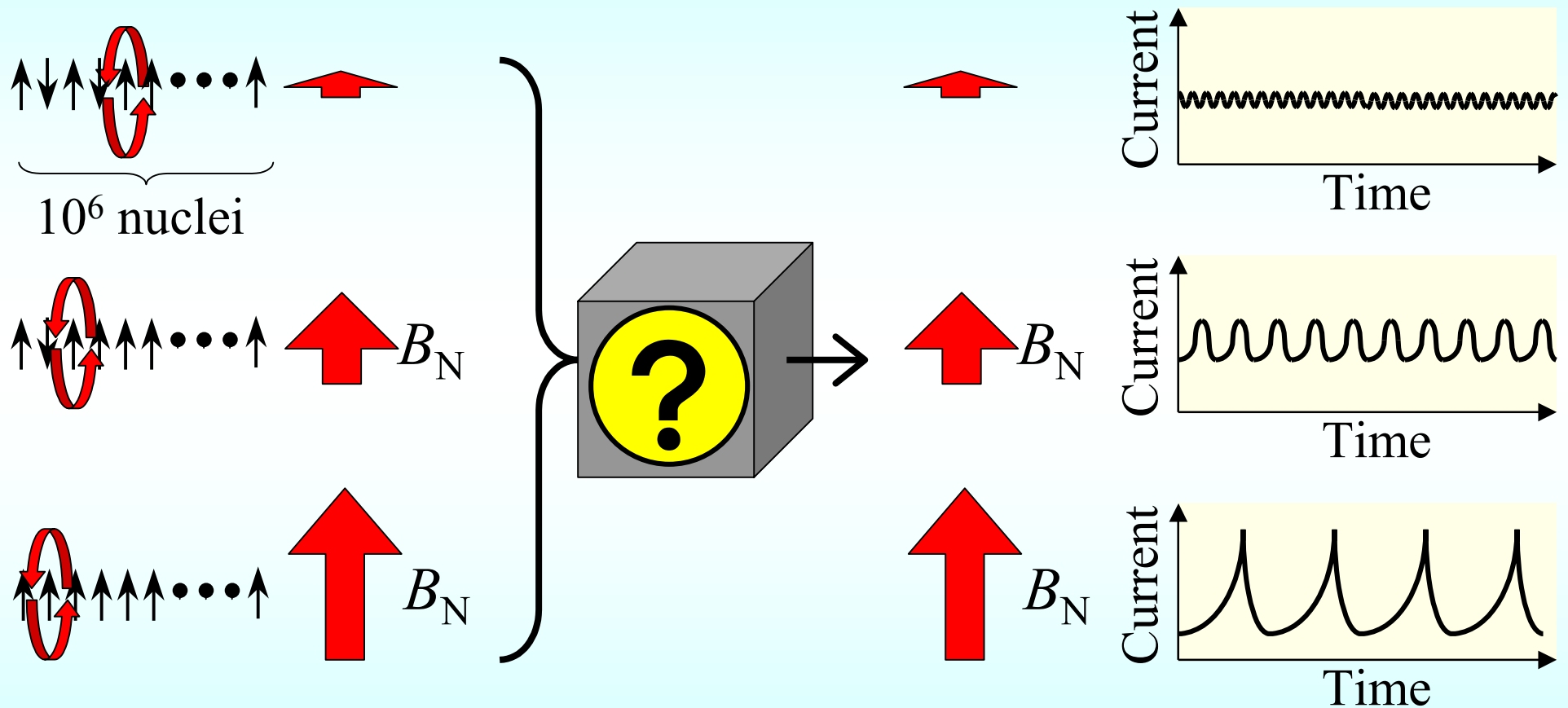

# Growth and decay of nuclear spin field $B_N$

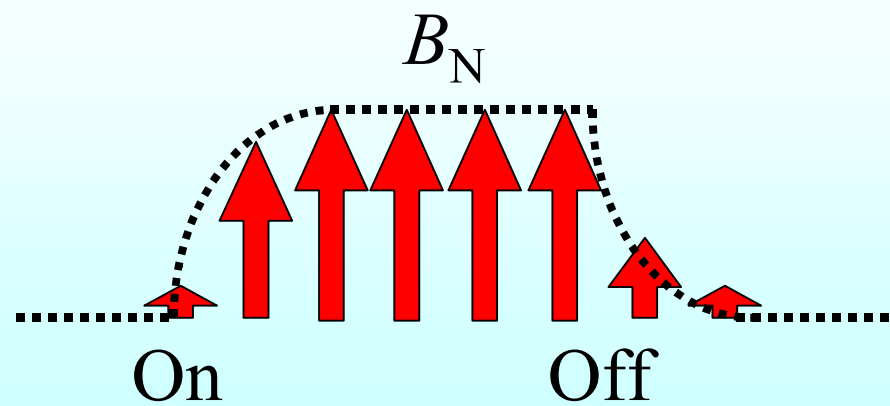
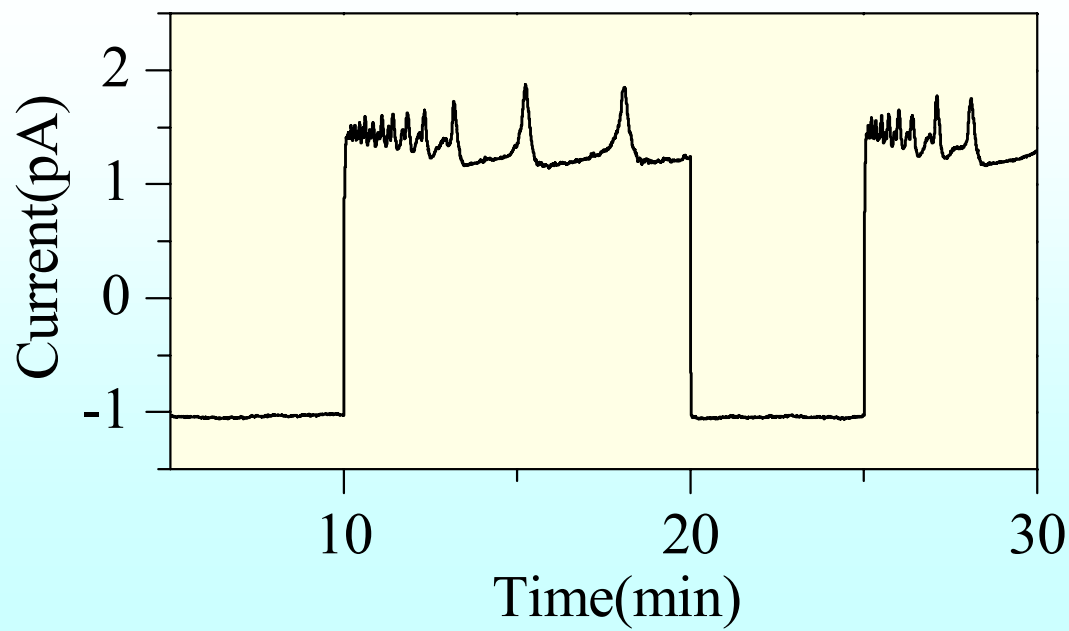
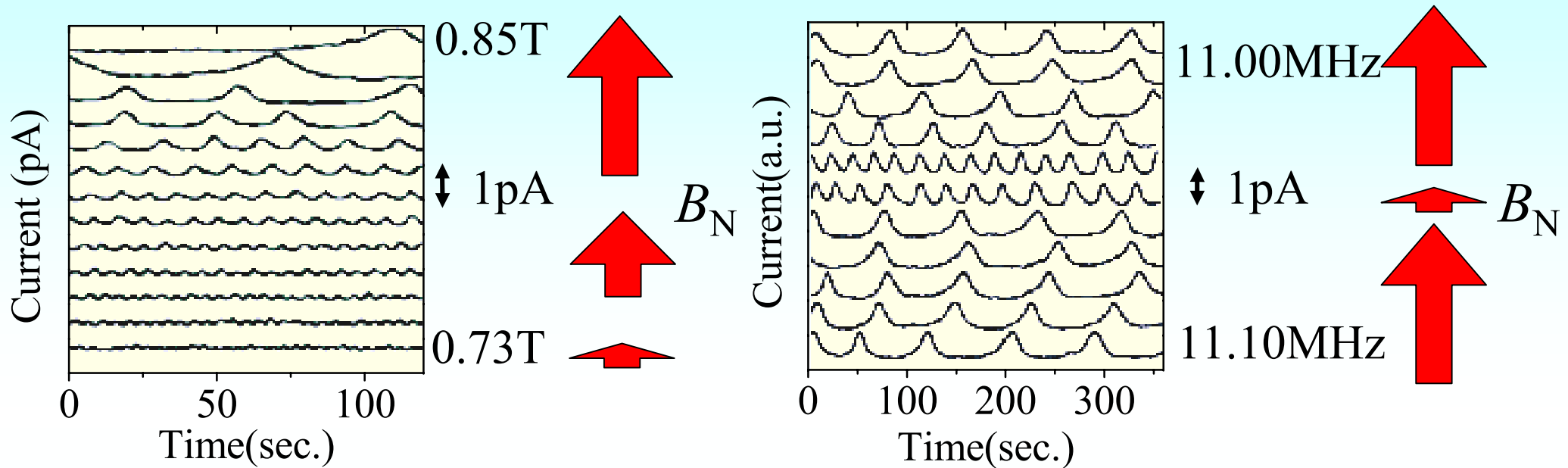

# Hyperfine interaction in QD

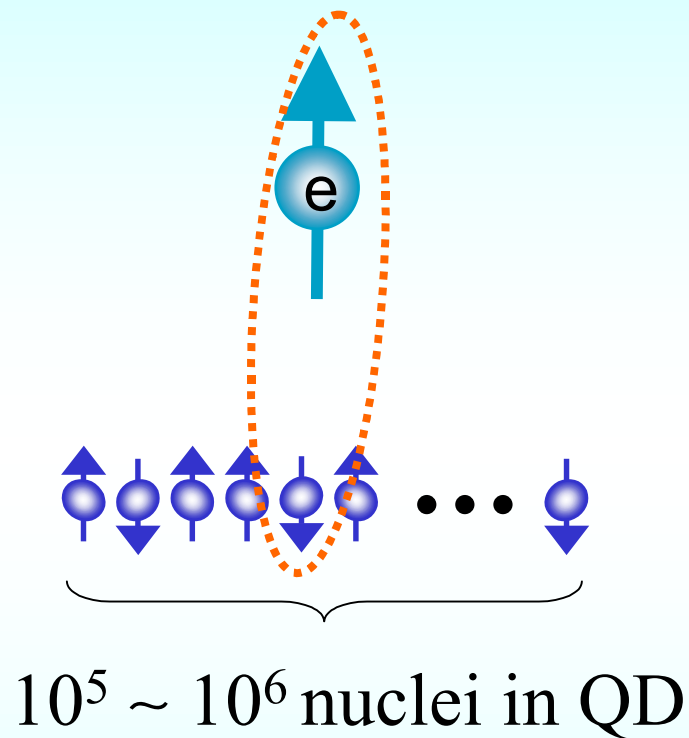

$$H_{\text{HF}} = A|\psi(\mathbf{x})|^2 \left( \frac{I_+ S_- + I_- S_+}{2} + I_Z S_Z \right)$$

Energy associated with spin flip ( $B=1\text{T}$ )

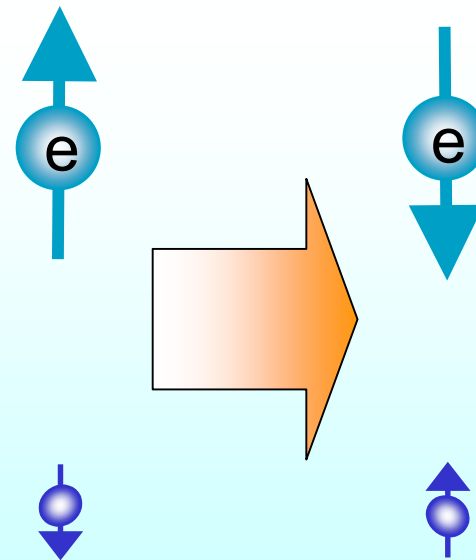

Electron in GaAs  
 $\sim 25\mu\text{eV}$

$^{71}\text{Ga}$  nuclear  
 $\sim 53\text{neV}$

# Charge & spin electronic states of $N=2$ double dot (1)

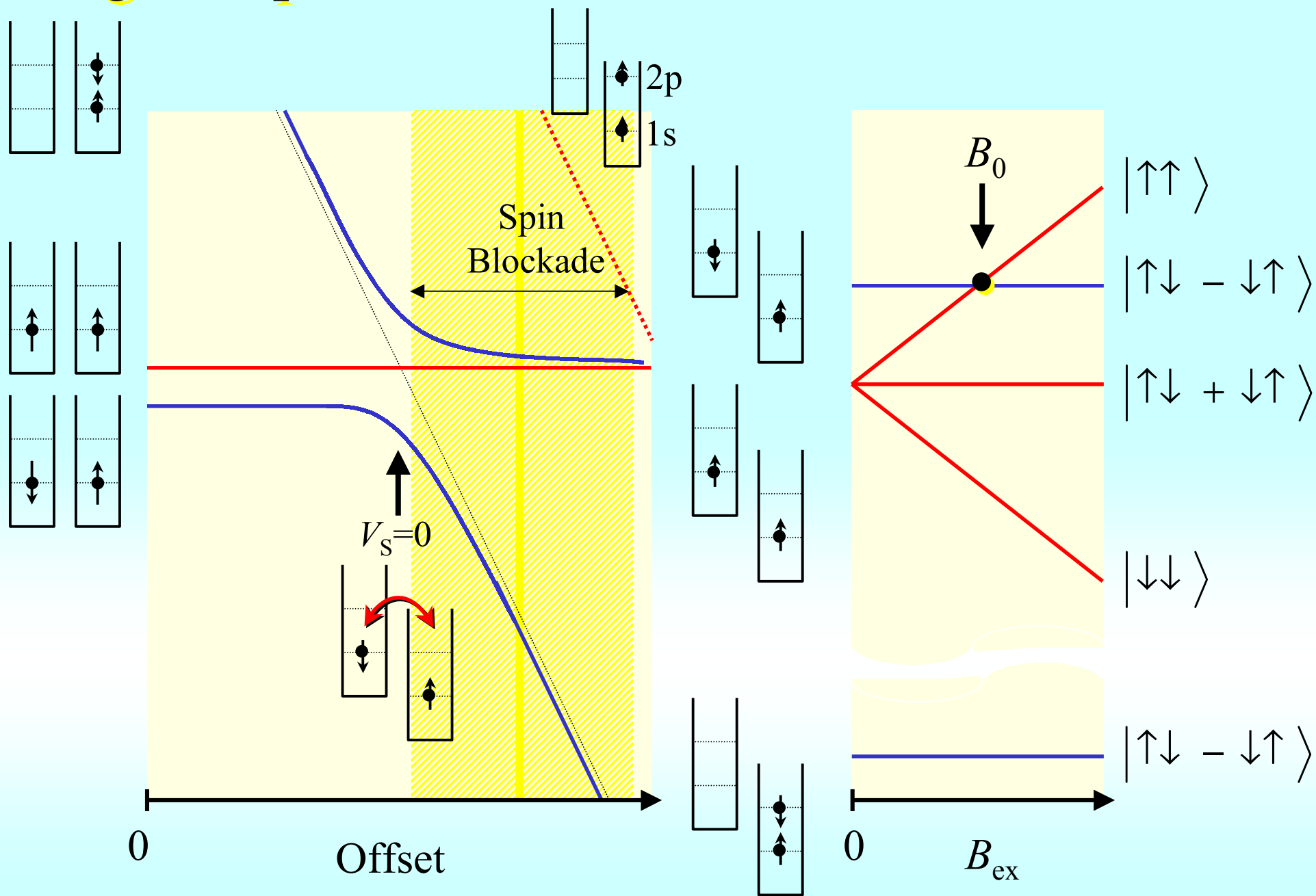

# Charge & spin electronic states of $N=2$ double dot (1)

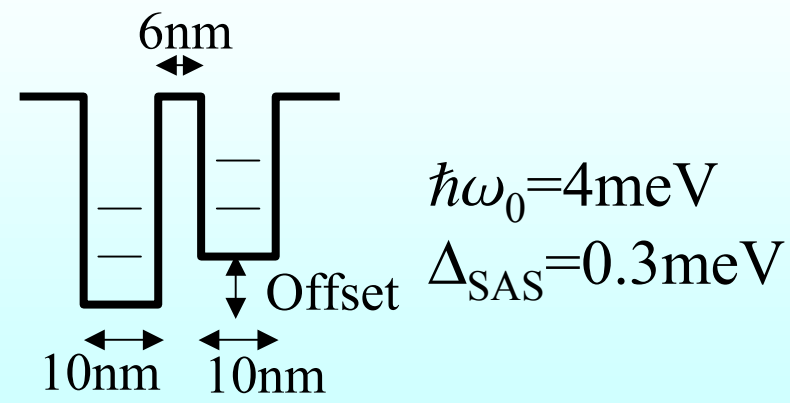
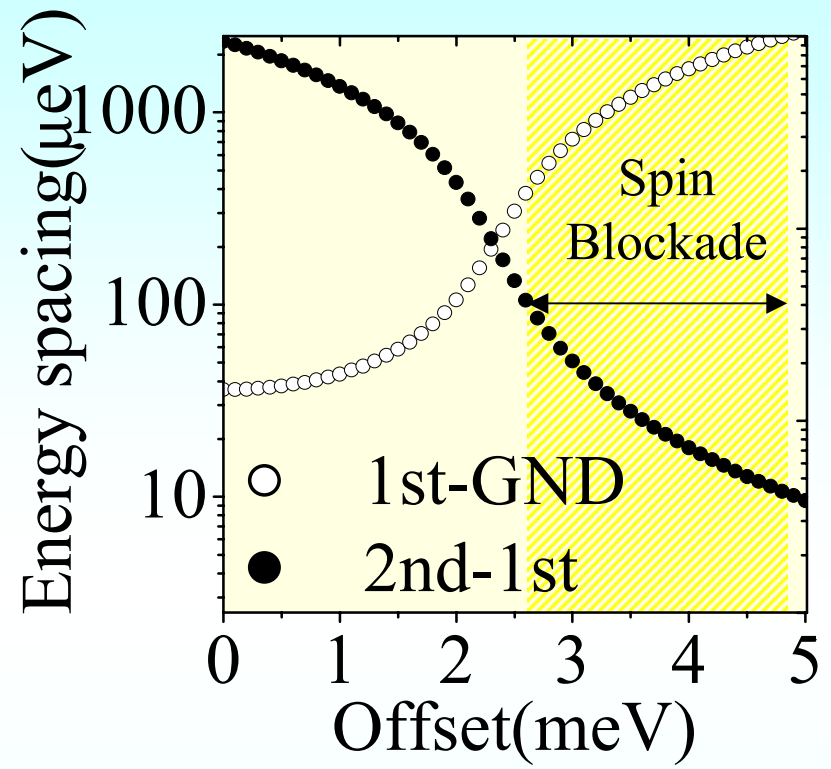
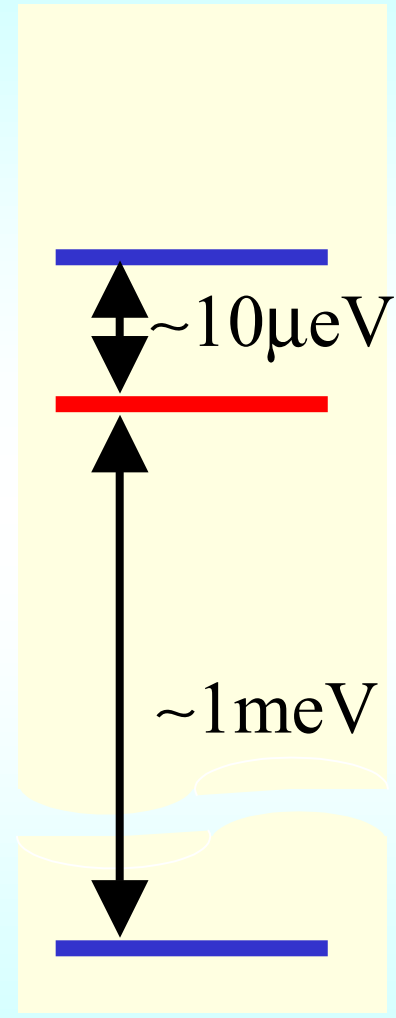
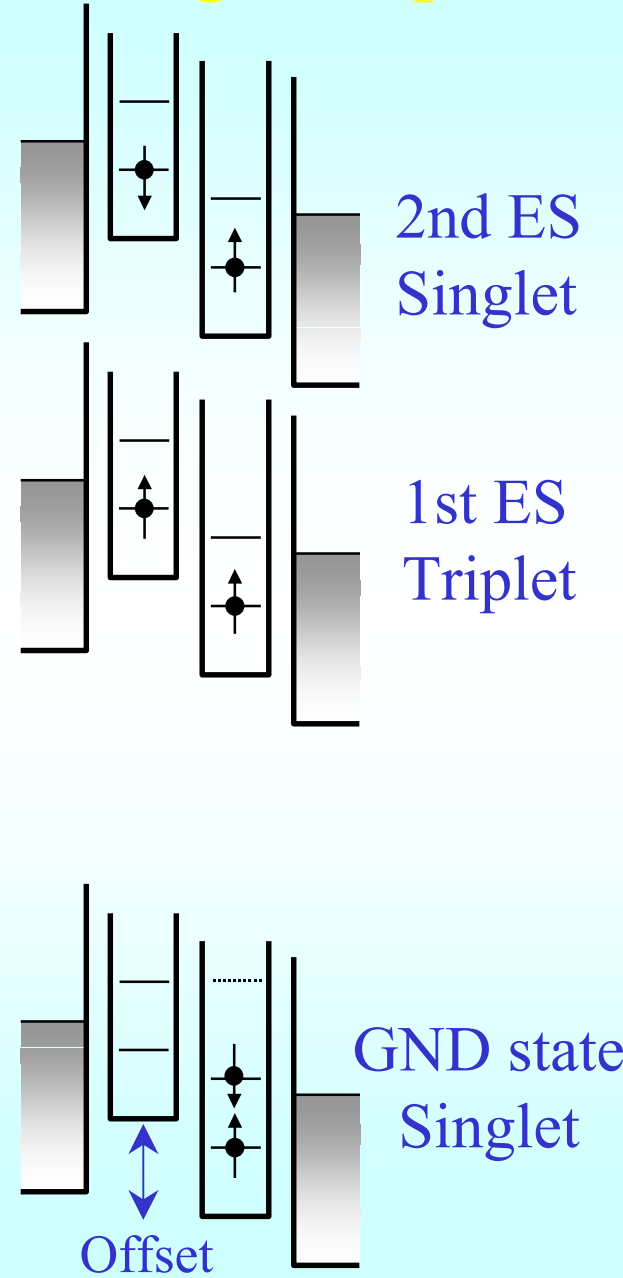

# Charge & spin electronic states of $N=2$ double dot (2)

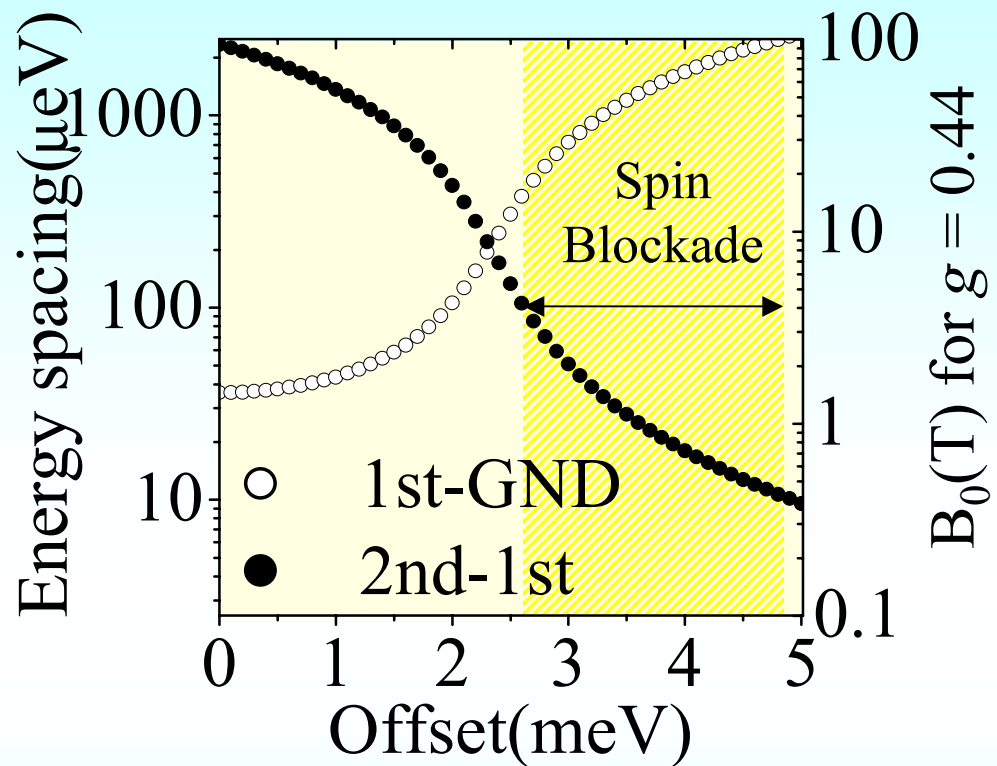
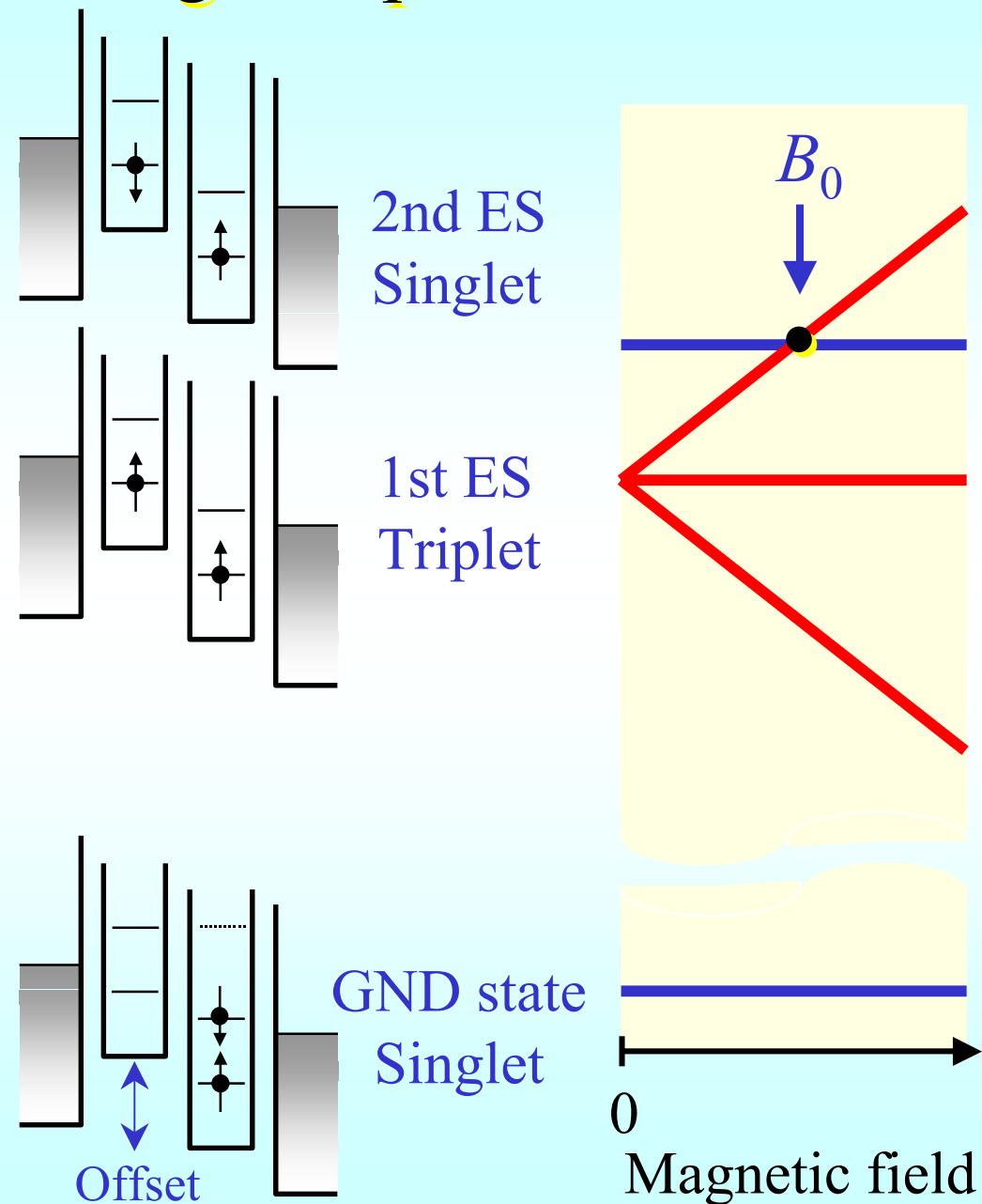

Flip-flop scattering occur at  $B_0$  from  $S_Z=1$  triplet to singlet

$B_0$  can be tuned by  $B$  and  $V$

# “Spin-blockade orientation” of nuclear spins in QD at $B_0$

$S_Z=1$  triplet

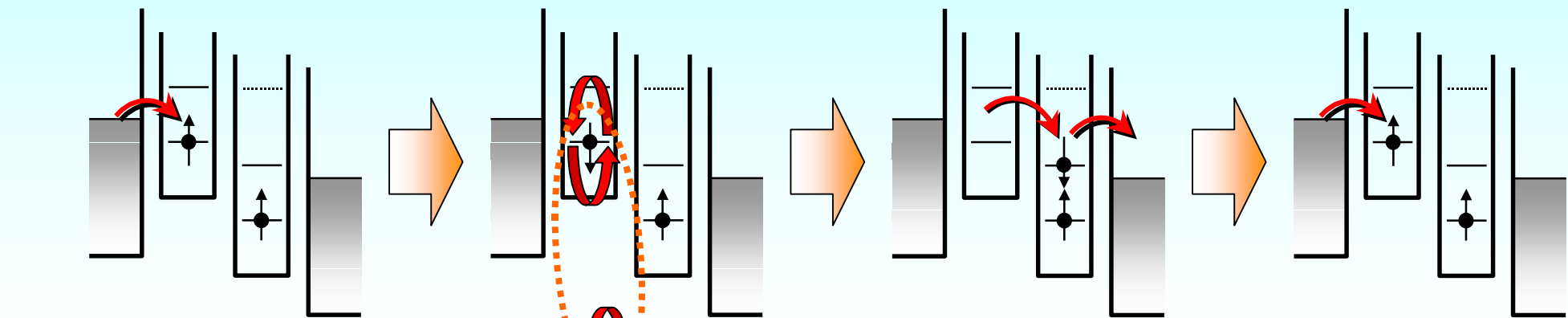

$\langle I \rangle = 0$   $\uparrow\downarrow\uparrow\downarrow\uparrow\cdots\uparrow$

$10^5 \sim 10^6$  nuclei

Triplet lifetime  $\approx 100$ ns

Singlet lifetime  $\approx 1$ ns



Flipped electron spin is “immediately removed”.

Nuclear spin  $T_1 \approx 10$ min



Accumulation of flopped nuclei.

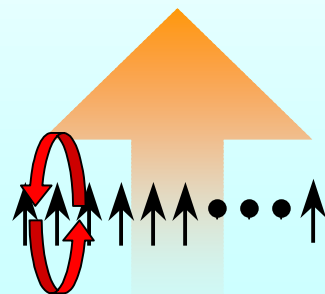
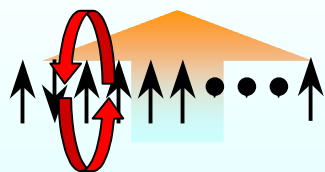

$\langle I \rangle \neq 0$

# Summary

- ◆ In weakly coupled double quantum dot we have observed current rectification due to Pauli exclusion.
- ◆ Small ( $\sim 1\text{pA}$ ) leakage current in the spin-blocked quantum dot shows time-dependent current oscillation.

Dynamic nuclear spin polarization by hyperfine mediated spin flip

- ② Why it oscillate?
- ② Why  $^{75}\text{As}$  NMR is not observed?

# Collaborator

D.G.Austing, Y. Tokura, S.Tarucha

 NTT Basic Research Laboratory

 ERATO Mesoscopic Correlation Project, JST

 National Research Council of Canada